



MODEL: RGEAZR iR Packaged Gas Electric Unit

FORM NO. RSC-878

Sure Comfort® RGEAZR iR Packaged Gas Electric Unit



RGEAZR

- Cooling Efficiency: 13.4 SEER2
- Nominal Sizes: 2-5 Tons [7.0-17.6 kW]



Table of Contents

Unit Features & Benefits.....	3-4
Model Number Identification	5
Options	6
General Data	7-19
General Data Notes.....	20
Gross Systems Performance Data	21-30
Indoor Airflow Performance.....	31-50
Electrical Data	51-57
Dimensional Data	58-59
Typical Installations.....	60
Accessories.....	61-68
Limited Warranty.....	69

Packaged Gas Electric Unit Features:

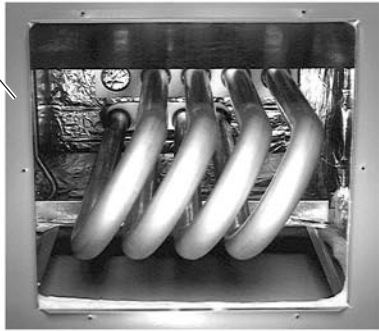
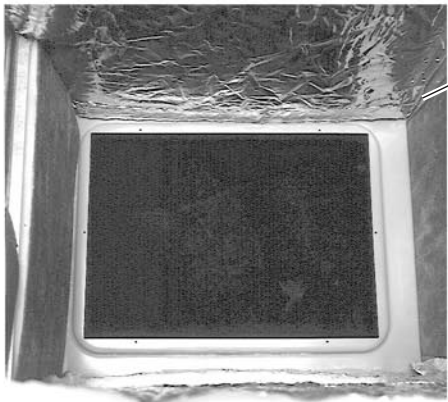
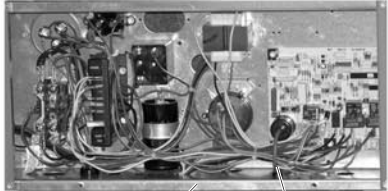
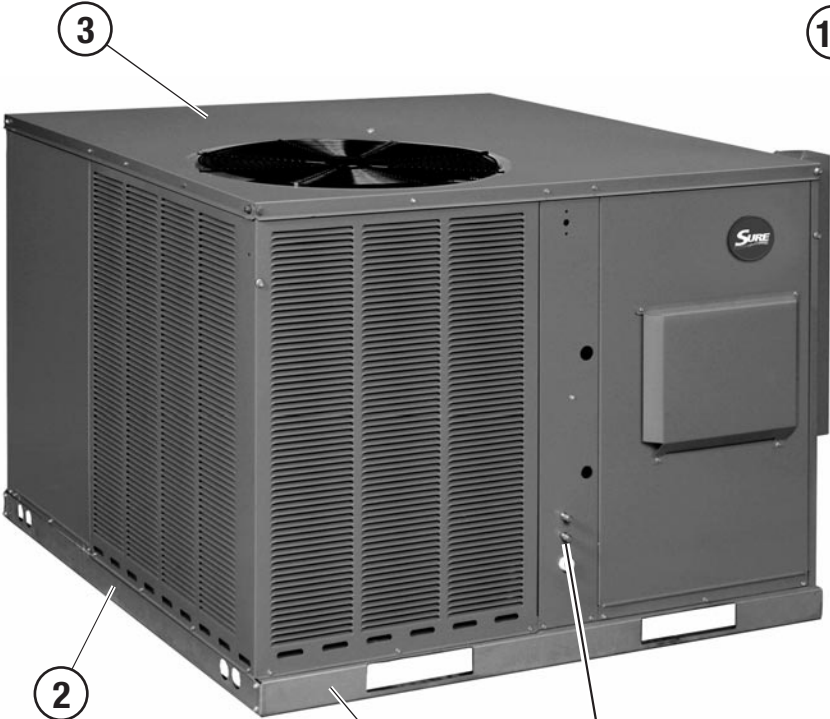
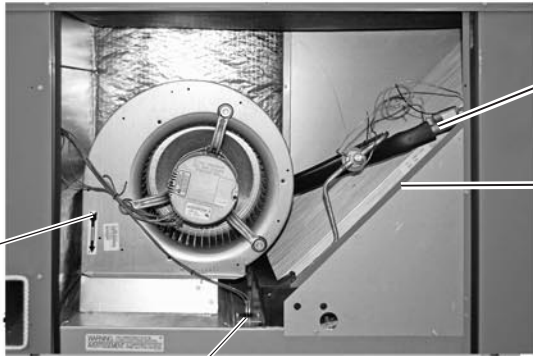
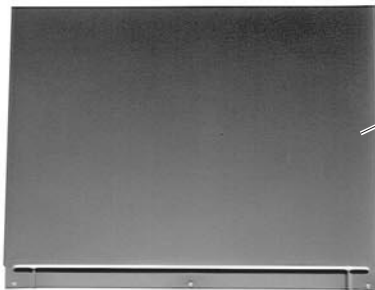



**RGEAZR
Features Below
Correspond
to Photos on Page 3**

1. All models feature Scroll compressors for maximum efficiency and quiet operation.
2. Louvered condenser compartment for protecting the coil against yard hazards and/or weather extremes.
3. One-piece top with a drip flange to help keep water out of the unit.
4. Supply and return air openings feature a one-inch tall flange to prevent water migration into the ductwork.
5. Access panels have “weep holes” and channels to further help manage water run-off.
6. Side and down discharge options available on all models. All models are shipped ready for horizontal application.
7. Easily accessible blower section complete with slide-out blower.
8. Refrigerant connections are conveniently located for easy service diagnostics.
9. Micro Channel evaporator and condenser delivers superior performance with less refrigerant charge and less weight than conventional copper tube/aluminum fin coils. In addition the all aluminum construction has superior protection against formicary corrosion and aluminum tube rubbing potential. It is easier to clean and has a more robust surface.
10. Inside the easily accessible furnace compartment is the draft inducer motor. This motor is specially designed for quiet reliable operation. In addition to the draft inducer motor, the in-shot gas burners and manifold efficiently regulate the flow of gas for combustion. These gas/electric units also feature direct-spark ignition and remote flame sensors for added reliability and efficiency.
11. Easily accessible control box.
12. Single point wiring simplifies installation.
13. Our gas/electric package units feature a tubular heat exchanger design. The heat exchanger is backed by a 10 year limited warranty. Models with a stainless steel heat exchanger installed in a residential application are backed by a limited lifetime warranty.
14. Thermal expansion valve standard on all models for superior superheat control, reliability, and energy efficiency at all operating conditions.
15. Filter drier standard on all models (not shown).
16. Rugged baserail included for improved installation and handling
17. Complete factory charged, wired and run tested.
18. Molded compressor plugs.
19. A double sloped evaporator coil drain pan assures all water is removed from the unit to improve indoor air quality.

Packaged Gas Electric

<u>R</u>	<u>GE</u>	<u>A</u>	<u>Z</u>	<u>R</u>	<u>024</u>	<u>A</u>	<u>J</u>	<u>T</u>	<u>04</u>	<u>1</u>	<u>N</u>	<u>A</u>
Brand	Product Category	Platform	Refrigerant	Tier	Capacity BTU/HR	Major Series	Voltage	Drive	Gas Heat Input	Gas Heat Configuration	Control	Minor Series
R - Sure Comfort	GE - Gas Electric	A - ResiPack Convertible	Z - R-410A	R - Base Tier (13.4 SEER2)	024 - 24,000 [7.03 kW] 030 - 30,000 [8.79 kW] 036 - 36,000 [10.55 kW] 042 - 42,000 [12.31 kW] 048 - 48,000 [14.07 kW] 060 - 60,000 [17.58 kW]	A - 1st Design	J - 1ph, 208-230/60 C - 3ph, 208-230/60 D - 3ph, 460/60	T - Constant Torque	04 - 40k BTU/h 06 - 60k BTU/h 08 - 80k BTU/h 10 - 100k BTU/h	1 - Single-Stage X - Single-Stage Low NOx U - Single-Stage Ultra Low NOx	N - Non-Communicating	A - 1st Design

[] Designates Metric Conversions

Available Models		
Standard	Low NOx (40ng/J)	Ultra Low NOx (14 ng/J)
RGEAZR024AJT041NA	RGEAZR024AJT04XNA	RGEAZR024AJT04UNA
RGEAZR024AJT061NA	RGEAZR024AJT06XNA	RGEAZR024AJT06UNA
RGEAZR024AJT081NA	RGEAZR024AJT08XNA	
RGEAZR030AJT041NA	RGEAZR030AJT04XNA	RGEAZR030AJT04UNA
RGEAZR030AJT061NA	RGEAZR030AJT06XNA	RGEAZR030AJT06UNA
RGEAZR030AJT081NA	RGEAZR030AJT08XNA	
RGEAZR036ACT061NA	RGEAZR036ACT06XNA	RGEAZR036ACT06UNA
RGEAZR036ACT081NA	RGEAZR036ACT08XNA	RGEAZR036ACT08UNA
RGEAZR036ACT101NA	RGEAZR036ACT10XNA	
RGEAZR036ADT061NA	RGEAZR036ADT06XNA	RGEAZR036ADT06UNA
RGEAZR036ADT081NA	RGEAZR036ADT08XNA	RGEAZR036ADT08UNA
RGEAZR036ADT101NA	RGEAZR036ADT10XNA	
RGEAZR036AJT061NA	RGEAZR036AJT06XNA	RGEAZR036AJT06UNA
RGEAZR036AJT081NA	RGEAZR036AJT08XNA	RGEAZR036AJT08UNA
RGEAZR036AJT101NA	RGEAZR036AJT10XNA	
RGEAZR042ACT081NA	RGEAZR042ACT08XNA	RGEAZR042ACT08UNA
RGEAZR042ACT101NA	RGEAZR042ACT10XNA	
RGEAZR042AJT081NA	RGEAZR042AJT08XNA	RGEAZR042AJT08UNA
RGEAZR042AJT101NA	RGEAZR042AJT10XNA	
RGEAZR048ACT081NA	RGEAZR048ACT08XNA	RGEAZR048ACT08UNA
RGEAZR048ACT101NA	RGEAZR048ACT10XNA	RGEAZR048ACT10UNA
RGEAZR048ADT081NA	RGEAZR048ADT08XNA	
RGEAZR048ADT101NA	RGEAZR048ADT10XNA	RGEAZR048ADT10UNA
RGEAZR048AJT081NA	RGEAZR048AJT08XNA	RGEAZR048AJT08UNA
RGEAZR048AJT101NA	RGEAZR048AJT10XNA	RGEAZR048AJT10UNA
RGEAZR060ACT081NA	RGEAZR060ACT08XNA	
RGEAZR060ACT101NA	RGEAZR060ACT10XNA	RGEAZR060ACT10UNA
RGEAZR060ADT081NA	RGEAZR060ADT08XNA	
RGEAZR060ADT101NA	RGEAZR060ADT10XNA	RGEAZR060ADT10UNA
RGEAZR060AJT081NA	RGEAZR060AJT08XNA	
RGEAZR060AJT101NA	RGEAZR060AJT10XNA	RGEAZR060AJT10UNA

NOTE: **Bold** represents 2-stage cooling models.

Instructions for Factory Installed Option(s) Selection

Note: Three characters following the model number will be utilized to designate a factory-installed option or combination of options. If no factory option(s) is required, nothing follows the model number.

After a basic rooftop model is selected, choose a *three-character* option code from the FACTORY INSTALLED OPTION SELECTION TABLE.

FACTORY INSTALLED OPTION CODES

Option Code	Stainless Steel Heat Exchanger
AJA	X

"x" indicates factory installed option.

Example: No Option

RGEAZR036AJT081NA

Example: Option with Stainless Steel Heat Exchanger

RGEAZR036AJT081NAAJA

Notes: ULN models standard with Stainless Steel Heat Exchanger

Factory installed economizer is not available.

NOMINAL SIZES 2-5 TONS [7.0-17.6 kW]

Model RGEAZR Series	024AJT041/X	024AJT04U	024AJT061/X	024AJT06U
Cooling Performance¹				CONTINUED →
Gross Cooling Capacity Btu [kW]	23,600 [6.91]	23,600 [6.91]	23,600 [6.91]	23,600 [6.91]
EER/SEER ²	10.6/13.4	10.6/13.4	10.6/13.4	10.6/13.4
Nominal CFM/AHRI Rated CFM [L/s]	800/810 [378/382]	800/810 [378/382]	800/810 [378/382]	800/810 [378/382]
AHRI Net Cooling Capacity Btu [kW]	23,000 [6.74]	23,000 [6.74]	23,000 [6.74]	23,000 [6.74]
Net Sensible Capacity Btu [kW]	16,700 [4.89]	16,700 [4.89]	16,700 [4.89]	16,700 [4.89]
Net Latent Capacity Btu [kW]	6,300 [1.85]	6,300 [1.85]	6,300 [1.85]	6,300 [1.85]
Net System Power kW	2.04	2.04	2.04	2.04
Heating Performance (Gas)⁴				
Heating Input Btu [kW]	40,000 [11.72]	40,000 [11.72]	60,000 [17.58]	60,000 [17.58]
Heating Output Btu [kW]	32,000 [9.38]	32,800 [9.61]	48,000 [14.06]	49,200 [14.42]
Temperature Rise Range °F [°C]	25-55 [13.9-30.6]	30-60 [16.7-33.3]	40-70 [22.2-38.9]	40-70 [22.2-38.9]
AFUE %	81	81	81	81
Steady State Efficiency (%)	82	82	82	82
No. Burners	2	1	3	1
No. Stages	1	1	1	1
Gas Connection Pipe Size in. [mm]	0.5 [12.7]	0.5 [12.7]	0.5 [12.7]	0.5 [12.7]
Compressor				
No./Type	1/Scroll	1/Scroll	1/Scroll	1/Scroll
Outdoor Sound Rating (dB)⁵	77	77	77	77
Outdoor Coil - Fin Type	Louvered	Louvered	Louvered	Louvered
Tube Type	MicroChannel	MicroChannel	MicroChannel	MicroChannel
MicroChannel Depth in. [mm]	0.472 [12]	0.472 [12]	0.472 [12]	0.472 [12]
Face Area sq. ft. [sq. m]	7.19 [0.67]	7.19 [0.67]	7.19 [0.67]	7.19 [0.67]
Rows / FPI [FPcm]	1 / 23 [9]	1 / 23 [9]	1 / 23 [9]	1 / 23 [9]
Indoor Coil - Fin Type	Louvered	Louvered	Louvered	Louvered
Tube Type	MicroChannel	MicroChannel	MicroChannel	MicroChannel
MicroChannel Depth in. [mm]	1 [25.4]	1 [25.4]	1 [25.4]	1 [25.4]
Face Area sq. ft. [sq. m]	3.54 [0.33]	3.54 [0.33]	3.54 [0.33]	3.54 [0.33]
Rows / FPI [FPcm]	1 / 20 [8]	1 / 20 [8]	1 / 20 [8]	1 / 20 [8]
Refrigerant Control	TX Valves	TX Valves	TX Valves	TX Valves
Drain Connection No./Size in. [mm]	1/0.75 [19.05]	1/0.75 [19.05]	1/0.75 [19.05]	1/0.75 [19.05]
Outdoor Fan - Type	Propeller	Propeller	Propeller	Propeller
No. Used/Diameter in. [mm]	1/22 [558.8]	1/22 [558.8]	1/22 [558.8]	1/22 [558.8]
Drive Type/No. Speeds	Direct/1	Direct/1	Direct/1	Direct/1
CFM [L/s]	2500 [1180]	2500 [1180]	2500 [1180]	2500 [1180]
No. Motors/HP	1 at 1/3 HP	1 at 1/3 HP	1 at 1/3 HP	1 at 1/3 HP
Motor RPM	825	825	825	825
Indoor Fan - Type	FC Centrifugal	FC Centrifugal	FC Centrifugal	FC Centrifugal
No. Used/Diameter in. [mm]	1/10x9 [254x229]	1/10x9 [254x229]	1/10x9 [254x229]	1/10x9 [254x229]
Drive Type	Direct	Direct	Direct	Direct
No. Speeds	Multiple	Multiple	Multiple	Multiple
No. Motors	1	1	1	1
Motor HP	1/3	1/3	1/3	1/3
Motor RPM	1050	1050	1050	1050
Motor Frame Size	48	48	48	48
Filter - Type	Field Supplied	Field Supplied	Field Supplied	Field Supplied
Furnished	No	No	No	No
(NO.) Size Recommended in. [mm x mm x mm]	(1)1x24x24 [25x610x610]	(1)1x24x24 [25x610x610]	(1)1x24x24 [25x610x610]	(1)1x24x24 [25x610x610]
Refrigerant Charge Oz. [g]	45.6 [1293]	45.6 [1293]	45.6 [1293]	45.6 [1293]
Weights				
Net Weight lbs. [kg]	384 [174]	384 [174]	389 [176]	389 [176]
Ship Weight lbs. [kg]	392 [178]	392 [178]	397 [180]	397 [180]

See Page 20 for Notes.

[] Designates Metric Conversions

NOMINAL SIZES 2-5 TONS [7.0-17.6 kW]

Model RGEAZR Series	024AJT081/X	030AJT041/X	030AJT04U	030AJT061/X
Cooling Performance¹				CONTINUED →
Gross Cooling Capacity Btu [kW]	23,600 [6.91]	29,400 [8.61]	29,400 [8.61]	29,400 [8.61]
EER/SEER ²	10.6/13.4	10.6/13.4	10.6/13.4	10.6/13.4
Nominal CFM/AHRI Rated CFM [L/s]	800/810 [378/382]	1000/980 [472/462]	1000/980 [472/462]	1000/980 [472/462]
AHRI Net Cooling Capacity Btu [kW]	23,000 [6.74]	28,400 [8.32]	28,400 [8.32]	28,400 [8.32]
Net Sensible Capacity Btu [kW]	16,700 [4.89]	21,100 [6.18]	21,100 [6.18]	21,100 [6.18]
Net Latent Capacity Btu [kW]	6,300 [1.85]	7,300 [2.14]	7,300 [2.14]	7,300 [2.14]
Net System Power kW	2.04	2.49	2.49	2.49
Heating Performance (Gas)⁴				
Heating Input Btu [kW]	80,000 [23.44]	40,000 [11.72]	40,000 [11.72]	60,000 [17.58]
Heating Output Btu [kW]	65,000 [19.04]	32,000 [9.38]	32,800 [9.61]	48,000 [14.06]
Temperature Rise Range °F [°C]	35-65 [19.4-36.1]	25-55 [13.9-30.6]	30-60 [16.7-33.3]	40-70 [22.2-38.9]
AFUE %	81	81	81	81
Steady State Efficiency (%)	82	82	82	82
No. Burners	4	2	1	3
No. Stages	1	1	1	1
Gas Connection Pipe Size in. [mm]	0.5 [12.7]	0.5 [12.7]	0.5 [12.7]	0.5 [12.7]
Compressor				
No./Type	1/Scroll	1/Scroll	1/Scroll	1/Scroll
Outdoor Sound Rating (dB)⁵	77	79	79	79
Outdoor Coil - Fin Type	Louvered	Louvered	Louvered	Louvered
Tube Type	MicroChannel	MicroChannel	MicroChannel	MicroChannel
MicroChannel Depth in. [mm]	0.472 [12]	0.709 [18]	0.709 [18]	0.709 [18]
Face Area sq. ft. [sq. m]	7.19 [0.67]	7.06 [0.66]	7.06 [0.66]	7.06 [0.66]
Rows / FPI [FPcm]	1 / 23 [9]	1 / 23 [9]	1 / 23 [9]	1 / 23 [9]
Indoor Coil - Fin Type	Louvered	Louvered	Louvered	Louvered
Tube Type	MicroChannel	MicroChannel	MicroChannel	MicroChannel
MicroChannel Depth in. [mm]	1 [25.4]	1 [25.4]	1 [25.4]	1 [25.4]
Face Area sq. ft. [sq. m]	3.54 [0.33]	3.54 [0.33]	3.54 [0.33]	3.54 [0.33]
Rows / FPI [FPcm]	1 / 20 [8]	1 / 20 [8]	1 / 20 [8]	1 / 20 [8]
Refrigerant Control	TX Valves	TX Valves	TX Valves	TX Valves
Drain Connection No./Size in. [mm]	1/0.75 [19.05]	1/0.75 [19.05]	1/0.75 [19.05]	1/0.75 [19.05]
Outdoor Fan - Type	Propeller	Propeller	Propeller	Propeller
No. Used/Diameter in. [mm]	1/22 [558.8]	1/22 [558.8]	1/22 [558.8]	1/22 [558.8]
Drive Type/No. Speeds	Direct/1	Direct/1	Direct/1	Direct/1
CFM [L/s]	2500 [1180]	2400 [1133]	2400 [1133]	2400 [1133]
No. Motors/HP	1 at 1/3 HP	1 at 1/3 HP	1 at 1/3 HP	1 at 1/3 HP
Motor RPM	825	825	825	825
Indoor Fan - Type	FC Centrifugal	FC Centrifugal	FC Centrifugal	FC Centrifugal
No. Used/Diameter in. [mm]	1/10x9 [254x229]	1/10x9 [254x229]	1/10x9 [254x229]	1/10x9 [254x229]
Drive Type	Direct	Direct	Direct	Direct
No. Speeds	Multiple	Multiple	Multiple	Multiple
No. Motors	1	1	1	1
Motor HP	1/3	1/2	1/2	1/2
Motor RPM	1050	1050	1050	1050
Motor Frame Size	48	48	48	48
Filter - Type	Field Supplied	Field Supplied	Field Supplied	Field Supplied
Furnished	No	No	No	No
(NO.) Size Recommended in. [mm x mm x mm]	(1)1x24x24 [25x610x610]	(1)1x24x24 [25x610x610]	(1)1x24x24 [25x610x610]	(1)1x24x24 [25x610x610]
Refrigerant Charge Oz. [g]	45.6 [1293]	48 [1361]	48 [1361]	48 [1361]
Weights				
Net Weight lbs. [kg]	394 [179]	384 [174]	384 [174]	389 [176]
Ship Weight lbs. [kg]	402 [182]	392 [178]	392 [178]	397 [180]

See Page 20 for Notes.

[] Designates Metric Conversions

NOMINAL SIZES 2-5 TONS [7.0-17.6 kW]

Model RGEAZR Series	030AJT06U	030AJT081/X	036ACT061/X	036ACT06U
Cooling Performance¹				CONTINUED →
Gross Cooling Capacity Btu [kW]	29,400 [8.61]	29,400 [8.61]	35,200 [10.31]	35,200 [10.31]
EER/SEER ²	10.6/13.4	10.6/13.4	11/14	11/14
Nominal CFM/AHRI Rated CFM [L/s]	1000/980 [472/462]	1000/980 [472/462]	1200/1180 [566/557]	1200/1180 [566/557]
AHRI Net Cooling Capacity Btu [kW]	28,400 [8.32]	28,400 [8.32]	34,200 [10.02]	34,200 [10.02]
Net Sensible Capacity Btu [kW]	21,100 [6.18]	21,100 [6.18]	25,100 [7.35]	25,100 [7.35]
Net Latent Capacity Btu [kW]	7,300 [2.14]	7,300 [2.14]	9,100 [2.67]	9,100 [2.67]
Net System Power kW	2.49	2.49	2.81	2.81
Heating Performance (Gas)⁴				
Heating Input Btu [kW]	60,000 [17.58]	80,000 [23.44]	60,000 [17.58]	60,000 [17.58]
Heating Output Btu [kW]	49,200 [14.42]	65,000 [19.04]	48,000 [14.06]	49,200 [14.42]
Temperature Rise Range °F [°C]	40-70 [22.2-38.9]	35-65 [19.4-36.1]	40-70 [22.2-38.9]	40-70 [22.2-38.9]
AFUE %	81	81	81	81
Steady State Efficiency (%)	82	82	82	82
No. Burners	1	4	3	1
No. Stages	1	1	1	1
Gas Connection Pipe Size in. [mm]	0.5 [12.7]	0.5 [12.7]	0.5 [12.7]	0.5 [12.7]
Compressor				
No./Type	1/Scroll	1/Scroll	1/Scroll	1/Scroll
Outdoor Sound Rating (dB)⁵	79	79	75	75
Outdoor Coil - Fin Type	Louvered	Louvered	Louvered	Louvered
Tube Type	MicroChannel	MicroChannel	MicroChannel	MicroChannel
MicroChannel Depth in. [mm]	0.709 [18]	0.709 [18]	0.709 [18]	0.709 [18]
Face Area sq. ft. [sq. m]	7.06 [0.66]	7.06 [0.66]	9.78 [0.91]	9.78 [0.91]
Rows / FPI [FPcm]	1 / 23 [9]	1 / 23 [9]	1 / 23 [9]	1 / 23 [9]
Indoor Coil - Fin Type	Louvered	Louvered	Louvered	Louvered
Tube Type	MicroChannel	MicroChannel	MicroChannel	MicroChannel
MicroChannel Depth in. [mm]	1 [25.4]	1 [25.4]	1 [25.4]	1 [25.4]
Face Area sq. ft. [sq. m]	3.54 [0.33]	3.54 [0.33]	3.54 [0.33]	3.54 [0.33]
Rows / FPI [FPcm]	1 / 20 [8]	1 / 20 [8]	1 / 20 [8]	1 / 20 [8]
Refrigerant Control	TX Valves	TX Valves	TX Valves	TX Valves
Drain Connection No./Size in. [mm]	1/0.75 [19.05]	1/0.75 [19.05]	1/0.75 [19.05]	1/0.75 [19.05]
Outdoor Fan - Type	Propeller	Propeller	Propeller	Propeller
No. Used/Diameter in. [mm]	1/22 [558.8]	1/22 [558.8]	1/22 [558.8]	1/22 [558.8]
Drive Type/No. Speeds	Direct/1	Direct/1	Direct/1	Direct/1
CFM [L/s]	2400 [1133]	2400 [1133]	3250 [1534]	3250 [1534]
No. Motors/HP	1 at 1/3 HP	1 at 1/3 HP	1 at 1/3 HP	1 at 1/3 HP
Motor RPM	825	825	825	825
Indoor Fan - Type	FC Centrifugal	FC Centrifugal	FC Centrifugal	FC Centrifugal
No. Used/Diameter in. [mm]	1/10x9 [254x229]	1/10x9 [254x229]	1/12x9 [305x229]	1/12x9 [305x229]
Drive Type	Direct	Direct	Direct	Direct
No. Speeds	Multiple	Multiple	Multiple	Multiple
No. Motors	1	1	1	1
Motor HP	1/2	1/2	1	1
Motor RPM	1050	1050	1050	1050
Motor Frame Size	48	48	48	48
Filter - Type	Field Supplied	Field Supplied	Field Supplied	Field Supplied
Furnished	No	No	No	No
(NO.) Size Recommended in. [mm x mm x mm]	(1)1x24x24 [25x610x610]	(1)1x24x24 [25x610x610]	(1)1x24x24 [25x610x610]	(1)1x24x24 [25x610x610]
Refrigerant Charge Oz. [g]	48 [1361]	48 [1361]	49.6 [1406]	49.6 [1406]
Weights				
Net Weight lbs. [kg]	389 [176]	394 [179]	398 [181]	398 [181]
Ship Weight lbs. [kg]	397 [180]	402 [182]	406 [184]	406 [184]

See Page 20 for Notes.

[] Designates Metric Conversions

NOMINAL SIZES 2-5 TONS [7.0-17.6 kW]

Model RGEAZR Series	036ACT081/X	036ACT08U	036ACT101/X	036ADT061/X
Cooling Performance¹				CONTINUED →
Gross Cooling Capacity Btu [kW]	35,200 [10.31]	35,200 [10.31]	35,200 [10.31]	35,200 [10.31]
EER/SEER ²	11/14	11/14	11/14	11/14
Nominal CFM/AHRI Rated CFM [L/s]	1200/1180 [566/557]	1200/1180 [566/557]	1200/1180 [566/557]	1200/1180 [566/557]
AHRI Net Cooling Capacity Btu [kW]	34,200 [10.02]	34,200 [10.02]	34,200 [10.02]	34,200 [10.02]
Net Sensible Capacity Btu [kW]	25,100 [7.35]	25,100 [7.35]	25,100 [7.35]	25,100 [7.35]
Net Latent Capacity Btu [kW]	9,100 [2.67]	9,100 [2.67]	9,100 [2.67]	9,100 [2.67]
Net System Power kW	2.81	2.81	2.81	2.81
Heating Performance (Gas)⁴				
Heating Input Btu [kW]	80,000 [23.44]	80,000 [23.44]	100,000 [29.3]	60,000 [17.58]
Heating Output Btu [kW]	65,000 [19.04]	65,600 [19.22]	81,000 [23.73]	48,000 [14.06]
Temperature Rise Range °F [°C]	35-65 [19.4-36.1]	40-70 [22.2-38.9]	45-75 [25-41.7]	40-70 [22.2-38.9]
AFUE %	81	81	81	81
Steady State Efficiency (%)	82	82	82	82
No. Burners	4	1	5	3
No. Stages	1	1	1	1
Gas Connection Pipe Size in. [mm]	0.5 [12.7]	0.5 [12.7]	0.5 [12.7]	0.5 [12.7]
Compressor				
No./Type	1/Scroll	1/Scroll	1/Scroll	1/Scroll
Outdoor Sound Rating (dB)⁵	75	75	75	75
Outdoor Coil - Fin Type	Louvered	Louvered	Louvered	Louvered
Tube Type	MicroChannel	MicroChannel	MicroChannel	MicroChannel
MicroChannel Depth in. [mm]	0.709 [18]	0.709 [18]	0.709 [18]	0.709 [18]
Face Area sq. ft. [sq. m]	9.78 [0.91]	9.78 [0.91]	9.78 [0.91]	9.78 [0.91]
Rows / FPI [FPcm]	1 / 23 [9]	1 / 23 [9]	1 / 23 [9]	1 / 23 [9]
Indoor Coil - Fin Type	Louvered	Louvered	Louvered	Louvered
Tube Type	MicroChannel	MicroChannel	MicroChannel	MicroChannel
MicroChannel Depth in. [mm]	1 [25.4]	1 [25.4]	1 [25.4]	1 [25.4]
Face Area sq. ft. [sq. m]	3.54 [0.33]	3.54 [0.33]	3.54 [0.33]	3.54 [0.33]
Rows / FPI [FPcm]	1 / 20 [8]	1 / 20 [8]	1 / 20 [8]	1 / 20 [8]
Refrigerant Control	TX Valves	TX Valves	TX Valves	TX Valves
Drain Connection No./Size in. [mm]	1/0.75 [19.05]	1/0.75 [19.05]	1/0.75 [19.05]	1/0.75 [19.05]
Outdoor Fan - Type	Propeller	Propeller	Propeller	Propeller
No. Used/Diameter in. [mm]	1/22 [558.8]	1/22 [558.8]	1/22 [558.8]	1/22 [558.8]
Drive Type/No. Speeds	Direct/1	Direct/1	Direct/1	Direct/1
CFM [L/s]	3250 [1534]	3250 [1534]	3250 [1534]	3250 [1534]
No. Motors/HP	1 at 1/3 HP	1 at 1/3 HP	1 at 1/3 HP	1 at 1/3 HP
Motor RPM	825	825	825	825
Indoor Fan - Type	FC Centrifugal	FC Centrifugal	FC Centrifugal	FC Centrifugal
No. Used/Diameter in. [mm]	1/12x9 [305x229]	1/12x9 [305x229]	1/12x9 [305x229]	1/12x9 [305x229]
Drive Type	Direct	Direct	Direct	Direct
No. Speeds	Multiple	Multiple	Multiple	Multiple
No. Motors	1	1	1	1
Motor HP	1	1	1	1
Motor RPM	1050	1050	1050	1050
Motor Frame Size	48	48	48	48
Filter - Type	Field Supplied	Field Supplied	Field Supplied	Field Supplied
Furnished	No	No	No	No
(NO.) Size Recommended in. [mm x mm x mm]	(1)1x24x24 [25x610x610]	(1)1x24x24 [25x610x610]	(1)1x24x24 [25x610x610]	(1)1x24x24 [25x610x610]
Refrigerant Charge Oz. [g]	49.6 [1406]	49.6 [1406]	49.6 [1406]	49.6 [1406]
Weights				
Net Weight lbs. [kg]	403 [183]	403 [183]	408 [185]	398 [181]
Ship Weight lbs. [kg]	411 [186]	411 [186]	416 [189]	406 [184]

See Page 20 for Notes.

[] Designates Metric Conversions

NOMINAL SIZES 2-5 TONS [7.0-17.6 kW]

Model RGEAZR Series	036ADT06U	036ADT081/X	036ADT08U	036ADT101/X
Cooling Performance¹				CONTINUED →
Gross Cooling Capacity Btu [kW]	35,200 [10.31]	35,200 [10.31]	35,200 [10.31]	35,200 [10.31]
EER/SEER ²	11/14	11/14	11/14	11/14
Nominal CFM/AHRI Rated CFM [L/s]	1200/1180 [566/557]	1200/1180 [566/557]	1200/1180 [566/557]	1200/1180 [566/557]
AHRI Net Cooling Capacity Btu [kW]	34,200 [10.02]	34,200 [10.02]	34,200 [10.02]	34,200 [10.02]
Net Sensible Capacity Btu [kW]	25,100 [7.35]	25,100 [7.35]	25,100 [7.35]	25,100 [7.35]
Net Latent Capacity Btu [kW]	9,100 [2.67]	9,100 [2.67]	9,100 [2.67]	9,100 [2.67]
Net System Power kW	2.81	2.81	2.81	2.81
Heating Performance (Gas)⁴				
Heating Input Btu [kW]	60,000 [17.58]	80,000 [23.44]	80,000 [23.44]	100,000 [29.3]
Heating Output Btu [kW]	49,200 [14.42]	65,000 [19.04]	65,600 [19.22]	81,000 [23.73]
Temperature Rise Range °F [°C]	40-70 [22.2-38.9]	35-65 [19.4-36.1]	40-70 [22.2-38.9]	45-75 [25-41.7]
AFUE %	81	81	81	81
Steady State Efficiency (%)	82	82	82	82
No. Burners	1	4	1	5
No. Stages	1	1	1	1
Gas Connection Pipe Size in. [mm]	0.5 [12.7]	0.5 [12.7]	0.5 [12.7]	0.5 [12.7]
Compressor				
No./Type	1/Scroll	1/Scroll	1/Scroll	1/Scroll
Outdoor Sound Rating (dB)⁵	75	75	75	75
Outdoor Coil - Fin Type	Louvered	Louvered	Louvered	Louvered
Tube Type	MicroChannel	MicroChannel	MicroChannel	MicroChannel
MicroChannel Depth in. [mm]	0.709 [18]	0.709 [18]	0.709 [18]	0.709 [18]
Face Area sq. ft. [sq. m]	9.78 [0.91]	9.78 [0.91]	9.78 [0.91]	9.78 [0.91]
Rows / FPI [FPcm]	1 / 23 [9]	1 / 23 [9]	1 / 23 [9]	1 / 23 [9]
Indoor Coil - Fin Type	Louvered	Louvered	Louvered	Louvered
Tube Type	MicroChannel	MicroChannel	MicroChannel	MicroChannel
MicroChannel Depth in. [mm]	1 [25.4]	1 [25.4]	1 [25.4]	1 [25.4]
Face Area sq. ft. [sq. m]	3.54 [0.33]	3.54 [0.33]	3.54 [0.33]	3.54 [0.33]
Rows / FPI [FPcm]	1 / 20 [8]	1 / 20 [8]	1 / 20 [8]	1 / 20 [8]
Refrigerant Control	TX Valves	TX Valves	TX Valves	TX Valves
Drain Connection No./Size in. [mm]	1/0.75 [19.05]	1/0.75 [19.05]	1/0.75 [19.05]	1/0.75 [19.05]
Outdoor Fan - Type	Propeller	Propeller	Propeller	Propeller
No. Used/Diameter in. [mm]	1/22 [558.8]	1/22 [558.8]	1/22 [558.8]	1/22 [558.8]
Drive Type/No. Speeds	Direct/1	Direct/1	Direct/1	Direct/1
CFM [L/s]	3250 [1534]	3250 [1534]	3250 [1534]	3250 [1534]
No. Motors/HP	1 at 1/3 HP	1 at 1/3 HP	1 at 1/3 HP	1 at 1/3 HP
Motor RPM	825	825	825	825
Indoor Fan - Type	FC Centrifugal	FC Centrifugal	FC Centrifugal	FC Centrifugal
No. Used/Diameter in. [mm]	1/12x9 [305x229]	1/12x9 [305x229]	1/12x9 [305x229]	1/12x9 [305x229]
Drive Type	Direct	Direct	Direct	Direct
No. Speeds	Multiple	Multiple	Multiple	Multiple
No. Motors	1	1	1	1
Motor HP	1	1	1	1
Motor RPM	1050	1050	1050	1050
Motor Frame Size	48	48	48	48
Filter - Type	Field Supplied	Field Supplied	Field Supplied	Field Supplied
Furnished	No	No	No	No
(NO.) Size Recommended in. [mm x mm x mm]	(1)1x24x24 [25x610x610]	(1)1x24x24 [25x610x610]	(1)1x24x24 [25x610x610]	(1)1x24x24 [25x610x610]
Refrigerant Charge Oz. [g]	49.6 [1406]	49.6 [1406]	49.6 [1406]	49.6 [1406]
Weights				
Net Weight lbs. [kg]	398 [181]	403 [183]	403 [183]	408 [185]
Ship Weight lbs. [kg]	406 [184]	411 [186]	411 [186]	416 [189]

See Page 20 for Notes.

[] Designates Metric Conversions

NOMINAL SIZES 2-5 TONS [7.0-17.6 kW]

Model RGEAZR Series	036AJT061/X	036AJT06U	036AJT081/X	036AJT08U
Cooling Performance¹				CONTINUED →
Gross Cooling Capacity Btu [kW]	35,600 [10.43]	35,600 [10.43]	35,600 [10.43]	35,600 [10.43]
EER/SEER ²	10.6/13.4	10.6/13.4	10.6/13.4	10.6/13.4
Nominal CFM/AHRI Rated CFM [L/s]	1200/1180 [566/557]	1200/1180 [566/557]	1200/1180 [566/557]	1200/1180 [566/557]
AHRI Net Cooling Capacity Btu [kW]	34,200 [10.02]	34,200 [10.02]	34,200 [10.02]	34,200 [10.02]
Net Sensible Capacity Btu [kW]	24,900 [7.3]	24,900 [7.3]	24,900 [7.3]	24,900 [7.3]
Net Latent Capacity Btu [kW]	9,300 [2.72]	9,300 [2.72]	9,300 [2.72]	9,300 [2.72]
Net System Power kW	2.98	2.98	2.98	2.98
Heating Performance (Gas)⁴				
Heating Input Btu [kW]	60,000 [17.58]	60,000 [17.58]	80,000 [23.44]	80,000 [23.44]
Heating Output Btu [kW]	48,000 [14.06]	49,200 [14.42]	65,000 [19.04]	65,600 [19.22]
Temperature Rise Range °F [°C]	40-70 [22.2-38.9]	40-70 [22.2-38.9]	35-65 [19.4-36.1]	40-70 [22.2-38.9]
AFUE %	81	81	81	81
Steady State Efficiency (%)	82	82	82	82
No. Burners	3	1	4	1
No. Stages	1	1	1	1
Gas Connection Pipe Size in. [mm]	0.5 [12.7]	0.5 [12.7]	0.5 [12.7]	0.5 [12.7]
Compressor				
No./Type	1/Scroll	1/Scroll	1/Scroll	1/Scroll
Outdoor Sound Rating (dB)⁵	75	75	75	75
Outdoor Coil - Fin Type	Louvered	Louvered	Louvered	Louvered
Tube Type	MicroChannel	MicroChannel	MicroChannel	MicroChannel
MicroChannel Depth in. [mm]	0.709 [18]	0.709 [18]	0.709 [18]	0.709 [18]
Face Area sq. ft. [sq. m]	9.78 [0.91]	9.78 [0.91]	9.78 [0.91]	9.78 [0.91]
Rows / FPI [FPcm]	1 / 23 [9]	1 / 23 [9]	1 / 23 [9]	1 / 23 [9]
Indoor Coil - Fin Type	Louvered	Louvered	Louvered	Louvered
Tube Type	MicroChannel	MicroChannel	MicroChannel	MicroChannel
MicroChannel Depth in. [mm]	1 [25.4]	1 [25.4]	1 [25.4]	1 [25.4]
Face Area sq. ft. [sq. m]	3.54 [0.33]	3.54 [0.33]	3.54 [0.33]	3.54 [0.33]
Rows / FPI [FPcm]	1 / 20 [8]	1 / 20 [8]	1 / 20 [8]	1 / 20 [8]
Refrigerant Control	TX Valves	TX Valves	TX Valves	TX Valves
Drain Connection No./Size in. [mm]	1/0.75 [19.05]	1/0.75 [19.05]	1/0.75 [19.05]	1/0.75 [19.05]
Outdoor Fan - Type	Propeller	Propeller	Propeller	Propeller
No. Used/Diameter in. [mm]	1/22 [558.8]	1/22 [558.8]	1/22 [558.8]	1/22 [558.8]
Drive Type/No. Speeds	Direct/1	Direct/1	Direct/1	Direct/1
CFM [L/s]	3250 [1534]	3250 [1534]	3250 [1534]	3250 [1534]
No. Motors/HP	1 at 1/3 HP	1 at 1/3 HP	1 at 1/3 HP	1 at 1/3 HP
Motor RPM	825	825	825	825
Indoor Fan - Type	FC Centrifugal	FC Centrifugal	FC Centrifugal	FC Centrifugal
No. Used/Diameter in. [mm]	1/12x9 [305x229]	1/12x9 [305x229]	1/12x9 [305x229]	1/12x9 [305x229]
Drive Type	Direct	Direct	Direct	Direct
No. Speeds	Multiple	Multiple	Multiple	Multiple
No. Motors	1	1	1	1
Motor HP	1	1	1	1
Motor RPM	1050	1050	1050	1050
Motor Frame Size	48	48	48	48
Filter - Type	Field Supplied	Field Supplied	Field Supplied	Field Supplied
Furnished	No	No	No	No
(NO.) Size Recommended in. [mm x mm x mm]	(1)1x24x24 [25x610x610]	(1)1x24x24 [25x610x610]	(1)1x24x24 [25x610x610]	(1)1x24x24 [25x610x610]
Refrigerant Charge Oz. [g]	49.6 [1406]	49.6 [1406]	49.6 [1406]	49.6 [1406]
Weights				
Net Weight lbs. [kg]	398 [181]	398 [181]	403 [183]	403 [183]
Ship Weight lbs. [kg]	406 [184]	406 [184]	411 [186]	411 [186]

See Page 20 for Notes.

[] Designates Metric Conversions

NOMINAL SIZES 2-5 TONS [7.0-17.6 kW]

Model RGEAZR Series	036AJT101/X	042ACT081/X	042ACT08U	042ACT101/X
Cooling Performance¹				CONTINUED →
Gross Cooling Capacity Btu [kW]	35,600 [10.43]	42,000 [12.31]	42,000 [12.31]	42,000 [12.31]
EER/SEER ²	10.6/13.4	11/14	11/14	11/14
Nominal CFM/AHRI Rated CFM [L/s]	1200/1180 [566/557]	1400/1510 [661/713]	1400/1510 [661/713]	1400/1510 [661/713]
AHRI Net Cooling Capacity Btu [kW]	34,200 [10.02]	40,500 [11.87]	40,500 [11.87]	40,500 [11.87]
Net Sensible Capacity Btu [kW]	24,900 [7.3]	30,500 [8.94]	30,500 [8.94]	30,500 [8.94]
Net Latent Capacity Btu [kW]	9,300 [2.72]	10,000 [2.93]	10,000 [2.93]	10,000 [2.93]
Net System Power kW	2.98	3.45	3.45	3.45
Heating Performance (Gas)⁴				
Heating Input Btu [kW]	100,000 [29.3]	80,000 [23.44]	80,000 [23.44]	100,000 [29.3]
Heating Output Btu [kW]	81,000 [23.73]	65,000 [19.04]	65,600 [19.22]	81,000 [23.73]
Temperature Rise Range °F [°C]	45-75 [25-41.7]	35-65 [19.4-36.1]	40-70 [22.2-38.9]	45-75 [25-41.7]
AFUE %	81	81	81	81
Steady State Efficiency (%)	82	82	82	82
No. Burners	5	4	1	5
No. Stages	1	1	1	1
Gas Connection Pipe Size in. [mm]	0.5 [12.7]	0.5 [12.7]	0.5 [12.7]	0.5 [12.7]
Compressor				
No./Type	1/Scroll	1/Scroll	1/Scroll	1/Scroll
Outdoor Sound Rating (dB)⁵	75	77	77	77
Outdoor Coil - Fin Type	Louvered	Louvered	Louvered	Louvered
Tube Type	MicroChannel	MicroChannel	MicroChannel	MicroChannel
MicroChannel Depth in. [mm]	0.709 [18]	0.709 [18]	0.709 [18]	0.709 [18]
Face Area sq. ft. [sq. m]	9.78 [0.91]	16.18 [1.5]	16.18 [1.5]	16.18 [1.5]
Rows / FPI [FPcm]	1 / 23 [9]	1 / 23 [9]	1 / 23 [9]	1 / 23 [9]
Indoor Coil - Fin Type	Louvered	Louvered	Louvered	Louvered
Tube Type	MicroChannel	MicroChannel	MicroChannel	MicroChannel
MicroChannel Depth in. [mm]	1 [25.4]	1.26 [32]	1.26 [32]	1.26 [32]
Face Area sq. ft. [sq. m]	3.54 [0.33]	3.98 [0.37]	3.98 [0.37]	3.98 [0.37]
Rows / FPI [FPcm]	1 / 20 [8]	1 / 20 [8]	1 / 20 [8]	1 / 20 [8]
Refrigerant Control	TX Valves	TX Valves	TX Valves	TX Valves
Drain Connection No./Size in. [mm]	1/0.75 [19.05]	1/0.75 [19.05]	1/0.75 [19.05]	1/0.75 [19.05]
Outdoor Fan - Type	Propeller	Propeller	Propeller	Propeller
No. Used/Diameter in. [mm]	1/22 [558.8]	1/22 [558.8]	1/22 [558.8]	1/22 [558.8]
Drive Type/No. Speeds	Direct/1	Direct/1	Direct/1	Direct/1
CFM [L/s]	3250 [1534]	4300 [2029]	4300 [2029]	4300 [2029]
No. Motors/HP	1 at 1/3 HP	1 at 1/3 HP	1 at 1/3 HP	1 at 1/3 HP
Motor RPM	825	1050	1050	1050
Indoor Fan - Type	FC Centrifugal	FC Centrifugal	FC Centrifugal	FC Centrifugal
No. Used/Diameter in. [mm]	1/12x9 [305x229]	1/12x9 [305x229]	1/12x9 [305x229]	1/12x9 [305x229]
Drive Type	Direct	Direct	Direct	Direct
No. Speeds	Multiple	Multiple	Multiple	Multiple
No. Motors	1	1	1	1
Motor HP	1	3/4	3/4	3/4
Motor RPM	1050	1050	1050	1050
Motor Frame Size	48	48	48	48
Filter - Type	Field Supplied	Field Supplied	Field Supplied	Field Supplied
Furnished	No	No	No	No
(NO.) Size Recommended in. [mm x mm x mm]	(1)1x24x24 [25x610x610]	(1)1x24x24 [25x610x610]	(1)1x24x24 [25x610x610]	(1)1x24x24 [25x610x610]
Refrigerant Charge Oz. [g]	49.6 [1406]	72 [2041]	72 [2041]	72 [2041]
Weights				
Net Weight lbs. [kg]	408 [185]	468 [212]	468 [212]	473 [215]
Ship Weight lbs. [kg]	416 [189]	476 [216]	476 [216]	481 [218]

See Page 20 for Notes.

[] Designates Metric Conversions

NOMINAL SIZES 2-5 TONS [7.0-17.6 kW]

Model RGEAZR Series	042AJT081/X	042AJT08U	042AJT101/X	048ACT081/X
Cooling Performance¹				CONTINUED →
Gross Cooling Capacity Btu [kW]	42,500 [12.45]	42,500 [12.45]	42,500 [12.45]	48,000 [14.06]
EER/SEER ²	10.6/13.4	10.6/13.4	10.6/13.4	11/14
Nominal CFM/AHRI Rated CFM [L/s]	1400/1510 [661/713]	1400/1510 [661/713]	1400/1510 [661/713]	1600/1730 [755/816]
AHRI Net Cooling Capacity Btu [kW]	40,500 [11.87]	40,500 [11.87]	40,500 [11.87]	46,000 [13.48]
Net Sensible Capacity Btu [kW]	30,500 [8.94]	30,500 [8.94]	30,500 [8.94]	34,000 [9.96]
Net Latent Capacity Btu [kW]	10,000 [2.93]	10,000 [2.93]	10,000 [2.93]	12,000 [3.52]
Net System Power kW	3.6	3.6	3.6	4.11
Heating Performance (Gas)⁴				
Heating Input Btu [kW]	80,000 [23.44]	80,000 [23.44]	100,000 [29.3]	80,000 [23.44]
Heating Output Btu [kW]	65,000 [19.04]	65,600 [19.22]	81,000 [23.73]	65,000 [19.04]
Temperature Rise Range °F [°C]	35-65 [19.4-36.1]	40-70 [22.2-38.9]	45-75 [25-41.7]	35-65 [19.4-36.1]
AFUE %	81	81	81	81
Steady State Efficiency (%)	82	82	82	82
No. Burners	4	1	5	4
No. Stages	1	1	1	1
Gas Connection Pipe Size in. [mm]	0.5 [12.7]	0.5 [12.7]	0.5 [12.7]	0.5 [12.7]
Compressor				
No./Type	1/Scroll	1/Scroll	1/Scroll	1/Scroll
Outdoor Sound Rating (dB)⁵	77	77	77	76
Outdoor Coil - Fin Type	Louvered	Louvered	Louvered	Louvered
Tube Type	MicroChannel	MicroChannel	MicroChannel	MicroChannel
MicroChannel Depth in. [mm]	0.709 [18]	0.709 [18]	0.709 [18]	1 [25.4]
Face Area sq. ft. [sq. m]	16.18 [1.5]	16.18 [1.5]	16.18 [1.5]	15.37 [1.43]
Rows / FPI [FPcm]	1 / 23 [9]	1 / 23 [9]	1 / 23 [9]	1 / 23 [9]
Indoor Coil - Fin Type	Louvered	Louvered	Louvered	Louvered
Tube Type	MicroChannel	MicroChannel	MicroChannel	MicroChannel
MicroChannel Depth in. [mm]	1.26 [32]	1.26 [32]	1.26 [32]	1.26 [32]
Face Area sq. ft. [sq. m]	3.98 [0.37]	3.98 [0.37]	3.98 [0.37]	3.98 [0.37]
Rows / FPI [FPcm]	1 / 20 [8]	1 / 20 [8]	1 / 20 [8]	1 / 20 [8]
Refrigerant Control	TX Valves	TX Valves	TX Valves	TX Valves
Drain Connection No./Size in. [mm]	1/0.75 [19.05]	1/0.75 [19.05]	1/0.75 [19.05]	1/0.75 [19.05]
Outdoor Fan - Type	Propeller	Propeller	Propeller	Propeller
No. Used/Diameter in. [mm]	1/22 [558.8]	1/22 [558.8]	1/22 [558.8]	1/22 [558.8]
Drive Type/No. Speeds	Direct/1	Direct/1	Direct/1	Direct/1
CFM [L/s]	4300 [2029]	4300 [2029]	4300 [2029]	4150 [1958]
No. Motors/HP	1 at 1/3 HP	1 at 1/3 HP	1 at 1/3 HP	1 at 1/3 HP
Motor RPM	1050	1050	1050	1050
Indoor Fan - Type	FC Centrifugal	FC Centrifugal	FC Centrifugal	FC Centrifugal
No. Used/Diameter in. [mm]	1/12x9 [305x229]	1/12x9 [305x229]	1/12x9 [305x229]	1/12x9 [305x229]
Drive Type	Direct	Direct	Direct	Direct
No. Speeds	Multiple	Multiple	Multiple	Multiple
No. Motors	1	1	1	1
Motor HP	3/4	3/4	3/4	1
Motor RPM	1050	1050	1050	1050
Motor Frame Size	48	48	48	48
Filter - Type	Field Supplied	Field Supplied	Field Supplied	Field Supplied
Furnished	No	No	No	No
(NO.) Size Recommended in. [mm x mm x mm]	(1)1x24x24 [25x610x610]	(1)1x24x24 [25x610x610]	(1)1x24x24 [25x610x610]	(1)1x24x24 [25x610x610]
Refrigerant Charge Oz. [g]	72 [2041]	72 [2041]	72 [2041]	88 [2495]
Weights				
Net Weight lbs. [kg]	468 [212]	468 [212]	473 [215]	487 [221]
Ship Weight lbs. [kg]	476 [216]	476 [216]	481 [218]	495 [225]

See Page 20 for Notes.

[] Designates Metric Conversions

NOMINAL SIZES 2-5 TONS [7.0-17.6 kW]

Model RGEAZR Series	048ACT08U	048ACT101/X	048ACT10U	048ADT081/X
Cooling Performance¹				CONTINUED →
Gross Cooling Capacity Btu [kW]	48,000 [14.06]	48,000 [14.06]	48,000 [14.06]	48,000 [14.06]
EER/SEER ²	11/14	11/14	11/14	11/14
Nominal CFM/AHRI Rated CFM [L/s]	1600/1730 [755/816]	1600/1730 [755/816]	1600/1730 [755/816]	1600/1730 [755/816]
AHRI Net Cooling Capacity Btu [kW]	46,000 [13.48]	46,000 [13.48]	46,000 [13.48]	46,000 [13.48]
Net Sensible Capacity Btu [kW]	34,000 [9.96]	34,000 [9.96]	34,000 [9.96]	34,000 [9.96]
Net Latent Capacity Btu [kW]	12,000 [3.52]	12,000 [3.52]	12,000 [3.52]	12,000 [3.52]
Net System Power kW	4.11	4.11	4.11	4.11
Heating Performance (Gas)⁴				
Heating Input Btu [kW]	80,000 [23.44]	100,000 [29.3]	100,000 [29.3]	80,000 [23.44]
Heating Output Btu [kW]	65,600 [19.22]	81,000 [23.73]	82,000 [24.03]	65,000 [19.04]
Temperature Rise Range °F [°C]	40-70 [22.2-38.9]	45-75 [25-41.7]	40-70 [22.2-38.9]	35-65 [19.4-36.1]
AFUE %	81	81	81	81
Steady State Efficiency (%)	82	82	82	82
No. Burners	1	5	1	4
No. Stages	1	1	1	1
Gas Connection Pipe Size in. [mm]	0.5 [12.7]	0.5 [12.7]	0.5 [12.7]	0.5 [12.7]
Compressor				
No./Type	1/Scroll	1/Scroll	1/Scroll	1/Scroll
Outdoor Sound Rating (dB)⁵	76	76	76	76
Outdoor Coil - Fin Type	Louvered	Louvered	Louvered	Louvered
Tube Type	MicroChannel	MicroChannel	MicroChannel	MicroChannel
MicroChannel Depth in. [mm]	1 [25.4]	1 [25.4]	1 [25.4]	1 [25.4]
Face Area sq. ft. [sq. m]	15.37 [1.43]	15.37 [1.43]	15.37 [1.43]	15.37 [1.43]
Rows / FPI [FPcm]	1 / 23 [9]	1 / 23 [9]	1 / 23 [9]	1 / 23 [9]
Indoor Coil - Fin Type	Louvered	Louvered	Louvered	Louvered
Tube Type	MicroChannel	MicroChannel	MicroChannel	MicroChannel
MicroChannel Depth in. [mm]	1.26 [32]	1.26 [32]	1.26 [32]	1.26 [32]
Face Area sq. ft. [sq. m]	3.98 [0.37]	3.98 [0.37]	3.98 [0.37]	3.98 [0.37]
Rows / FPI [FPcm]	1 / 20 [8]	1 / 20 [8]	1 / 20 [8]	1 / 20 [8]
Refrigerant Control	TX Valves	TX Valves	TX Valves	TX Valves
Drain Connection No./Size in. [mm]	1/0.75 [19.05]	1/0.75 [19.05]	1/0.75 [19.05]	1/0.75 [19.05]
Outdoor Fan - Type	Propeller	Propeller	Propeller	Propeller
No. Used/Diameter in. [mm]	1/22 [558.8]	1/22 [558.8]	1/22 [558.8]	1/22 [558.8]
Drive Type/No. Speeds	Direct/1	Direct/1	Direct/1	Direct/1
CFM [L/s]	4150 [1958]	4150 [1958]	4150 [1958]	4150 [1958]
No. Motors/HP	1 at 1/3 HP	1 at 1/3 HP	1 at 1/3 HP	1 at 1/3 HP
Motor RPM	1050	1050	1050	1050
Indoor Fan - Type	FC Centrifugal	FC Centrifugal	FC Centrifugal	FC Centrifugal
No. Used/Diameter in. [mm]	1/12x9 [305x229]	1/12x9 [305x229]	1/12x9 [305x229]	1/12x9 [305x229]
Drive Type	Direct	Direct	Direct	Direct
No. Speeds	Multiple	Multiple	Multiple	Multiple
No. Motors	1	1	1	1
Motor HP	1	1	1	1
Motor RPM	1050	1050	1050	1050
Motor Frame Size	48	48	48	48
Filter - Type	Field Supplied	Field Supplied	Field Supplied	Field Supplied
Furnished	No	No	No	No
(NO.) Size Recommended in. [mm x mm x mm]	(1)1x24x24 [25x610x610]	(1)1x24x24 [25x610x610]	(1)1x24x24 [25x610x610]	(1)1x24x24 [25x610x610]
Refrigerant Charge Oz. [g]	88 [2495]	88 [2495]	88 [2495]	88 [2495]
Weights				
Net Weight lbs. [kg]	487 [221]	492 [223]	492 [223]	487 [221]
Ship Weight lbs. [kg]	495 [225]	500 [227]	500 [227]	495 [225]

See Page 20 for Notes.

[] Designates Metric Conversions

NOMINAL SIZES 2-5 TONS [7.0-17.6 kW]

Model RGEAZR Series	048ADT101/X	048ADT10U	048AJT081/X	048AJT08U
Cooling Performance¹				CONTINUED →
Gross Cooling Capacity Btu [kW]	48,000 [14.06]	48,000 [14.06]	48,500 [14.21]	48,500 [14.21]
EER/SEER ²	11/14	11/14	10.6/13.4	10.6/13.4
Nominal CFM/AHRI Rated CFM [L/s]	1600/1730 [755/816]	1600/1730 [755/816]	1600/1730 [755/816]	1600/1730 [755/816]
AHRI Net Cooling Capacity Btu [kW]	46,000 [13.48]	46,000 [13.48]	46,000 [13.48]	46,000 [13.48]
Net Sensible Capacity Btu [kW]	34,000 [9.96]	34,000 [9.96]	34,000 [9.96]	34,000 [9.96]
Net Latent Capacity Btu [kW]	12,000 [3.52]	12,000 [3.52]	12,000 [3.52]	12,000 [3.52]
Net System Power kW	4.11	4.11	4.33	4.33
Heating Performance (Gas)⁴				
Heating Input Btu [kW]	100,000 [29.3]	100,000 [29.3]	80,000 [23.44]	80,000 [23.44]
Heating Output Btu [kW]	81,000 [23.73]	82,000 [24.03]	65,000 [19.04]	65,600 [19.22]
Temperature Rise Range °F [°C]	45-75 [25-41.7]	40-70 [22.2-38.9]	35-65 [19.4-36.1]	40-70 [22.2-38.9]
AFUE %	81	81	81	81
Steady State Efficiency (%)	82	82	82	82
No. Burners	5	1	4	1
No. Stages	1	1	1	1
Gas Connection Pipe Size in. [mm]	0.5 [12.7]	0.5 [12.7]	0.5 [12.7]	0.5 [12.7]
Compressor				
No./Type	1/Scroll	1/Scroll	1/Scroll	1/Scroll
Outdoor Sound Rating (dB)⁵	76	76	76	76
Outdoor Coil - Fin Type	Louvered	Louvered	Louvered	Louvered
Tube Type	MicroChannel	MicroChannel	MicroChannel	MicroChannel
MicroChannel Depth in. [mm]	1 [25.4]	1 [25.4]	1 [25.4]	1 [25.4]
Face Area sq. ft. [sq. m]	15.37 [1.43]	15.37 [1.43]	15.37 [1.43]	15.37 [1.43]
Rows / FPI [FPcm]	1 / 23 [9]	1 / 23 [9]	1 / 23 [9]	1 / 23 [9]
Indoor Coil - Fin Type	Louvered	Louvered	Louvered	Louvered
Tube Type	MicroChannel	MicroChannel	MicroChannel	MicroChannel
MicroChannel Depth in. [mm]	1.26 [32]	1.26 [32]	1.26 [32]	1.26 [32]
Face Area sq. ft. [sq. m]	3.98 [0.37]	3.98 [0.37]	3.98 [0.37]	3.98 [0.37]
Rows / FPI [FPcm]	1 / 20 [8]	1 / 20 [8]	1 / 20 [8]	1 / 20 [8]
Refrigerant Control	TX Valves	TX Valves	TX Valves	TX Valves
Drain Connection No./Size in. [mm]	1/0.75 [19.05]	1/0.75 [19.05]	1/0.75 [19.05]	1/0.75 [19.05]
Outdoor Fan - Type	Propeller	Propeller	Propeller	Propeller
No. Used/Diameter in. [mm]	1/22 [558.8]	1/22 [558.8]	1/22 [558.8]	1/22 [558.8]
Drive Type/No. Speeds	Direct/1	Direct/1	Direct/1	Direct/1
CFM [L/s]	4150 [1958]	4150 [1958]	4150 [1958]	4150 [1958]
No. Motors/HP	1 at 1/3 HP	1 at 1/3 HP	1 at 1/3 HP	1 at 1/3 HP
Motor RPM	1050	1050	1050	1050
Indoor Fan - Type	FC Centrifugal	FC Centrifugal	FC Centrifugal	FC Centrifugal
No. Used/Diameter in. [mm]	1/12x9 [305x229]	1/12x9 [305x229]	1/12x9 [305x229]	1/12x9 [305x229]
Drive Type	Direct	Direct	Direct	Direct
No. Speeds	Multiple	Multiple	Multiple	Multiple
No. Motors	1	1	1	1
Motor HP	1	1	1	1
Motor RPM	1050	1050	1050	1050
Motor Frame Size	48	48	48	48
Filter - Type	Field Supplied	Field Supplied	Field Supplied	Field Supplied
Furnished	No	No	No	No
(NO.) Size Recommended in. [mm x mm x mm]	(1)1x24x24 [25x610x610]	(1)1x24x24 [25x610x610]	(1)1x24x24 [25x610x610]	(1)1x24x24 [25x610x610]
Refrigerant Charge Oz. [g]	88 [2495]	88 [2495]	88 [2495]	88 [2495]
Weights				
Net Weight lbs. [kg]	492 [223]	492 [223]	487 [221]	487 [221]
Ship Weight lbs. [kg]	500 [227]	500 [227]	495 [225]	495 [225]

See Page 20 for Notes.

[] Designates Metric Conversions

NOMINAL SIZES 2-5 TONS [7.0-17.6 kW]

Model RGEAZR Series	048AJT101/X	048AJT10U	060ACT081/X	060ACT101/X
Cooling Performance¹				CONTINUED →
Gross Cooling Capacity Btu [kW]	48,500 [14.21]	48,500 [14.21]	58,000 [16.99]	58,000 [16.99]
EER/SEER ²	10.6/13.4	10.6/13.4	11/14	11/14
Nominal CFM/AHRI Rated CFM [L/s]	1600/1730 [755/816]	1600/1730 [755/816]	2000/1700 [944/802]	2000/1700 [944/802]
AHRI Net Cooling Capacity Btu [kW]	46,000 [13.48]	46,000 [13.48]	56,000 [16.41]	56,000 [16.41]
Net Sensible Capacity Btu [kW]	34,000 [9.96]	34,000 [9.96]	40,000 [11.72]	40,000 [11.72]
Net Latent Capacity Btu [kW]	12,000 [3.52]	12,000 [3.52]	16,000 [4.69]	16,000 [4.69]
Net System Power kW	4.33	4.33	5.02	5.02
Heating Performance (Gas)⁴				
Heating Input Btu [kW]	100,000 [29.3]	100,000 [29.3]	80,000 [23.44]	100,000 [29.3]
Heating Output Btu [kW]	81,000 [23.73]	82,000 [24.03]	65,000 [19.04]	81,000 [23.73]
Temperature Rise Range °F [°C]	45-75 [25-41.7]	40-70 [22.2-38.9]	35-65 [19.4-36.1]	45-75 [25-41.7]
AFUE %	81	81	81	81
Steady State Efficiency (%)	82	82	82	82
No. Burners	5	1	4	5
No. Stages	1	1	1	1
Gas Connection Pipe Size in. [mm]	0.5 [12.7]	0.5 [12.7]	0.5 [12.7]	0.5 [12.7]
Compressor				
No./Type	1/Scroll	1/Scroll	1/Scroll	1/Scroll
Outdoor Sound Rating (dB)⁵	76	76	77	77
Outdoor Coil - Fin Type	Louvered	Louvered	Louvered	Louvered
Tube Type	MicroChannel	MicroChannel	MicroChannel	MicroChannel
MicroChannel Depth in. [mm]	1 [25.4]	1 [25.4]	1 [25.4]	1 [25.4]
Face Area sq. ft. [sq. m]	15.37 [1.43]	15.37 [1.43]	15.37 [1.43]	15.37 [1.43]
Rows / FPI [FPcm]	1 / 23 [9]	1 / 23 [9]	1 / 23 [9]	1 / 23 [9]
Indoor Coil - Fin Type	Louvered	Louvered	Louvered	Louvered
Tube Type	MicroChannel	MicroChannel	MicroChannel	MicroChannel
MicroChannel Depth in. [mm]	1.26 [32]	1.26 [32]	1.26 [32]	1.26 [32]
Face Area sq. ft. [sq. m]	3.98 [0.37]	3.98 [0.37]	3.96 [0.37]	3.96 [0.37]
Rows / FPI [FPcm]	1 / 20 [8]	1 / 20 [8]	1 / 20 [8]	1 / 20 [8]
Refrigerant Control	TX Valves	TX Valves	TX Valves	TX Valves
Drain Connection No./Size in. [mm]	1/0.75 [19.05]	1/0.75 [19.05]	1/0.75 [19.05]	1/0.75 [19.05]
Outdoor Fan - Type	Propeller	Propeller	Propeller	Propeller
No. Used/Diameter in. [mm]	1/22 [558.8]	1/22 [558.8]	1/22 [558.8]	1/22 [558.8]
Drive Type/No. Speeds	Direct/1	Direct/1	Direct/1	Direct/1
CFM [L/s]	4150 [1958]	4150 [1958]	4300 [2029]	4300 [2029]
No. Motors/HP	1 at 1/3 HP	1 at 1/3 HP	1 at 1/2 HP	1 at 1/2 HP
Motor RPM	1050	1050	1050	1050
Indoor Fan - Type	FC Centrifugal	FC Centrifugal	FC Centrifugal	FC Centrifugal
No. Used/Diameter in. [mm]	1/12x9 [305x229]	1/12x9 [305x229]	1/12x9 [305x229]	1/12x9 [305x229]
Drive Type	Direct	Direct	Direct	Direct
No. Speeds	Multiple	Multiple	Multiple	Multiple
No. Motors	1	1	1	1
Motor HP	1	1	1	1
Motor RPM	1050	1050	1050	1050
Motor Frame Size	48	48	48	48
Filter - Type	Field Supplied	Field Supplied	Field Supplied	Field Supplied
Furnished	No	No	No	No
(NO.) Size Recommended in. [mm x mm x mm]	(1)1x24x24 [25x610x610]	(1)1x24x24 [25x610x610]	(1)1x24x24 [25x610x610]	(1)1x24x24 [25x610x610]
Refrigerant Charge Oz. [g]	88 [2495]	88 [2495]	89.6 [2540]	89.6 [2540]
Weights				
Net Weight lbs. [kg]	492 [223]	492 [223]	490 [222]	495 [225]
Ship Weight lbs. [kg]	500 [227]	500 [227]	498 [226]	503 [228]

See Page 20 for Notes.

[] Designates Metric Conversions

NOMINAL SIZES 2-5 TONS [7.0-17.6 kW]

Model RGEAZR Series	060ACT10U	060ADT081/X	060ADT101/X	060ADT10U
Cooling Performance¹				CONTINUED →
Gross Cooling Capacity Btu [kW]	58,000 [16.99]	58,000 [16.99]	58,000 [16.99]	58,000 [16.99]
EER/SEER ²	11/14	11/14	11/14	11/14
Nominal CFM/AHRI Rated CFM [L/s]	2000/1700 [944/802]	2000/1700 [944/802]	2000/1700 [944/802]	2000/1700 [944/802]
AHRI Net Cooling Capacity Btu [kW]	56,000 [16.41]	56,000 [16.41]	56,000 [16.41]	56,000 [16.41]
Net Sensible Capacity Btu [kW]	40,000 [11.72]	40,000 [11.72]	40,000 [11.72]	40,000 [11.72]
Net Latent Capacity Btu [kW]	16,000 [4.69]	16,000 [4.69]	16,000 [4.69]	16,000 [4.69]
Net System Power kW	5.02	5.02	5.02	5.02
Heating Performance (Gas)⁴				
Heating Input Btu [kW]	100,000 [29.3]	80,000 [23.44]	100,000 [29.3]	100,000 [29.3]
Heating Output Btu [kW]	82,000 [24.03]	65,000 [19.04]	81,000 [23.73]	82,000 [24.03]
Temperature Rise Range °F [°C]	40-70 [22.2-38.9]	35-65 [19.4-36.1]	45-75 [25-41.7]	40-70 [22.2-38.9]
AFUE %	81	81	81	81
Steady State Efficiency (%)	82	82	82	82
No. Burners	1	4	5	1
No. Stages	1	1	1	1
Gas Connection Pipe Size in. [mm]	0.5 [12.7]	0.5 [12.7]	0.5 [12.7]	0.5 [12.7]
Compressor				
No./Type	1/Scroll	1/Scroll	1/Scroll	1/Scroll
Outdoor Sound Rating (dB)⁵	77	77	77	77
Outdoor Coil - Fin Type	Louvered	Louvered	Louvered	Louvered
Tube Type	MicroChannel	MicroChannel	MicroChannel	MicroChannel
MicroChannel Depth in. [mm]	1 [25.4]	1 [25.4]	1 [25.4]	1 [25.4]
Face Area sq. ft. [sq. m]	15.37 [1.43]	15.37 [1.43]	15.37 [1.43]	15.37 [1.43]
Rows / FPI [FPcm]	1 / 23 [9]	1 / 23 [9]	1 / 23 [9]	1 / 23 [9]
Indoor Coil - Fin Type	Louvered	Louvered	Louvered	Louvered
Tube Type	MicroChannel	MicroChannel	MicroChannel	MicroChannel
MicroChannel Depth in. [mm]	1.26 [32]	1.26 [32]	1.26 [32]	1.26 [32]
Face Area sq. ft. [sq. m]	3.96 [0.37]	3.96 [0.37]	3.96 [0.37]	3.96 [0.37]
Rows / FPI [FPcm]	1 / 20 [8]	1 / 20 [8]	1 / 20 [8]	1 / 20 [8]
Refrigerant Control	TX Valves	TX Valves	TX Valves	TX Valves
Drain Connection No./Size in. [mm]	1/0.75 [19.05]	1/0.75 [19.05]	1/0.75 [19.05]	1/0.75 [19.05]
Outdoor Fan - Type	Propeller	Propeller	Propeller	Propeller
No. Used/Diameter in. [mm]	1/22 [558.8]	1/22 [558.8]	1/22 [558.8]	1/22 [558.8]
Drive Type/No. Speeds	Direct/1	Direct/1	Direct/1	Direct/1
CFM [L/s]	4300 [2029]	4300 [2029]	4300 [2029]	4300 [2029]
No. Motors/HP	1 at 1/2 HP	1 at 1/2 HP	1 at 1/2 HP	1 at 1/2 HP
Motor RPM	1050	1050	1050	1050
Indoor Fan - Type	FC Centrifugal	FC Centrifugal	FC Centrifugal	FC Centrifugal
No. Used/Diameter in. [mm]	1/12x9 [305x229]	1/12x9 [305x229]	1/12x9 [305x229]	1/12x9 [305x229]
Drive Type	Direct	Direct	Direct	Direct
No. Speeds	Multiple	Multiple	Multiple	Multiple
No. Motors	1	1	1	1
Motor HP	1	1	1	1
Motor RPM	1050	1050	1050	1050
Motor Frame Size	48	48	48	48
Filter - Type	Field Supplied	Field Supplied	Field Supplied	Field Supplied
Furnished	No	No	No	No
(NO.) Size Recommended in. [mm x mm x mm]	(1)1x24x24 [25x610x610]	(1)1x24x24 [25x610x610]	(1)1x24x24 [25x610x610]	(1)1x24x24 [25x610x610]
Refrigerant Charge Oz. [g]	89.6 [2540]	89.6 [2540]	89.6 [2540]	89.6 [2540]
Weights				
Net Weight lbs. [kg]	495 [225]	490 [222]	495 [225]	495 [225]
Ship Weight lbs. [kg]	503 [228]	498 [226]	503 [228]	503 [228]

See Page 20 for Notes.

[] Designates Metric Conversions

NOMINAL SIZES 2-5 TONS [7.0-17.6 kW]

Model RGEAZR Series	060AJT081/X	060AJT101/X	060AJT10U
Cooling Performance¹			
Gross Cooling Capacity Btu [kW]	58,500 [17.14]	58,500 [17.14]	58,500 [17.14]
EER/SEER ²	10.6/13.4	10.6/13.4	10.6/13.4
Nominal CFM/AHRI Rated CFM [L/s]	2000/1700 [944/802]	2000/1700 [944/802]	2000/1700 [944/802]
AHRI Net Cooling Capacity Btu [kW]	56,000 [16.41]	56,000 [16.41]	56,000 [16.41]
Net Sensible Capacity Btu [kW]	40,000 [11.72]	40,000 [11.72]	40,000 [11.72]
Net Latent Capacity Btu [kW]	16,000 [4.69]	16,000 [4.69]	16,000 [4.69]
Net System Power kW	5.16	5.16	5.16
Heating Performance (Gas)⁴			
Heating Input Btu [kW]	80,000 [23.44]	100,000 [29.3]	100,000 [29.3]
Heating Output Btu [kW]	65,000 [19.04]	81,000 [23.73]	82,000 [24.03]
Temperature Rise Range °F [°C]	35-65 [19.4-36.1]	45-75 [25-41.7]	40-70 [22.2-38.9]
AFUE %	81	81	81
Steady State Efficiency (%)	82	82	82
No. Burners	4	5	1
No. Stages	1	1	1
Gas Connection Pipe Size in. [mm]	0.5 [12.7]	0.5 [12.7]	0.5 [12.7]
Compressor			
No./Type	1/Scroll	1/Scroll	1/Scroll
Outdoor Sound Rating (dB)⁵			
	77	77	77
Outdoor Coil - Fin Type			
Tube Type	Louvered	Louvered	Louvered
MicroChannel Depth in. [mm]	MicroChannel	MicroChannel	MicroChannel
Face Area sq. ft. [sq. m]	1 [25.4]	1 [25.4]	1 [25.4]
Rows / FPI [FPcm]	15.37 [1.43]	15.37 [1.43]	15.37 [1.43]
	1 / 23 [9]	1 / 23 [9]	1 / 23 [9]
Indoor Coil - Fin Type			
Tube Type	Louvered	Louvered	Louvered
MicroChannel Depth in. [mm]	MicroChannel	MicroChannel	MicroChannel
Face Area sq. ft. [sq. m]	1.26 [32]	1.26 [32]	1.26 [32]
Rows / FPI [FPcm]	3.96 [0.37]	3.96 [0.37]	3.96 [0.37]
	1 / 20 [8]	1 / 20 [8]	1 / 20 [8]
Refrigerant Control	TX Valves	TX Valves	TX Valves
Drain Connection No./Size in. [mm]	1/0.75 [19.05]	1/0.75 [19.05]	1/0.75 [19.05]
Outdoor Fan - Type			
No. Used/Diameter in. [mm]	Propeller	Propeller	Propeller
Drive Type/No. Speeds	1/22 [558.8]	1/22 [558.8]	1/22 [558.8]
CFM [L/s]	Direct/1	Direct/1	Direct/1
No. Motors/HP	4300 [2029]	4300 [2029]	4300 [2029]
Motor RPM	1 at 1/2 HP	1 at 1/2 HP	1 at 1/2 HP
	1050	1050	1050
Indoor Fan - Type			
No. Used/Diameter in. [mm]	FC Centrifugal	FC Centrifugal	FC Centrifugal
Drive Type	1/12x9 [305x229]	1/12x9 [305x229]	1/12x9 [305x229]
No. Speeds	Direct	Direct	Direct
No. Motors	Multiple	Multiple	Multiple
Motor HP	1	1	1
Motor RPM	1	1	1
Motor Frame Size	1050	1050	1050
	48	48	48
Filter - Type			
Furnished	Field Supplied	Field Supplied	Field Supplied
(NO.) Size Recommended in. [mm x mm x mm]	No	No	No
	(1)1x24x24 [25x610x610]	(1)1x24x24 [25x610x610]	(1)1x24x24 [25x610x610]
Refrigerant Charge Oz. [g]			
	89.6 [2540]	89.6 [2540]	89.6 [2540]
Weights			
Net Weight lbs. [kg]	490 [222]	495 [225]	495 [225]
Ship Weight lbs. [kg]	498 [226]	503 [228]	503 [228]

See Page 20 for Notes.

[] Designates Metric Conversions

NOTES:

1. Cooling Performance is rated at 95°F ambient, 80°F entering dry bulb, 67°F entering wet bulb. Gross capacity does not include the effect of fan motor heat. ARI capacity is net and includes the effect of fan motor heat. Units are suitable for operation to $\pm 20\%$ of nominal cfm. Units are certified in accordance with the Unitary Air Conditioner Equipment certification program, which is based on ARI Standard 210/240 or 360.
2. EER2 and/or SEER2 are rated at ARI conditions and in accordance with DOE test procedures for 1-Phase models. EER and/or SEER are rated at ARI conditions and in accordance with DOE test procedures for 3-Phase models.
3. Heating Performance limit settings and rating data were established and approved under laboratory test conditions using American National Standard Institute standards. Ratings shown are for elevations up to 2000 feet. For elevations above 2000 feet, ratings should be reduced at the rate of 4% for each 1000 feet above sea level.
4. AFUE is rated in accordance with DOE test procedures.
5. Outdoor Sound Rating shown is tested in accordance with ARI Standard 270.

GROSS SYSTEMS PERFORMANCE DATA—RGEAZR024AJT

ENTERING INDOOR AIR @ 80°F [26.7°C] dbE ①											
wbE		71°F [21.7°C]			67°F [19.4°C]			63°F [17.2°C]			
CFM [L/s]		900 [425]	810 [382]	700 [330]	900 [425]	810 [382]	700 [330]	900 [425]	810 [382]	700 [330]	
DR ①		0.17	0.19	0.22	0.17	0.19	0.22	0.17	0.19	0.22	
INDOOR DRY BULB TEMPERATURE °F [°C]	75 [23.9]	Total BTUH [kW] Sens BTUH [kW] Power	29.4 [8.6] 17.4 [5.1] 1.4	28.8 [8.4] 15.9 [4.7] 1.4	28.1 [8.2] 14.2 [4.2] 1.4	27.7 [8.1] 20.7 [6.1] 1.4	27.1 [7.9] 19.1 [5.6] 1.4	26.5 [7.8] 17.3 [5.1] 1.4	26.8 [7.9] 23.9 [7.0] 1.4	26.3 [7.7] 22.2 [6.5] 1.4	25.6 [7.5] 20.1 [5.9] 1.4
	80 [26.7]	Total BTUH [kW] Sens BTUH [kW] Power	28.5 [8.4] 16.9 [5.0] 1.5	27.9 [8.2] 15.5 [4.5] 1.5	27.3 [8.0] 14.0 [4.1] 1.5	26.8 [7.9] 20.2 [5.9] 1.5	26.3 [7.7] 18.7 [5.5] 1.5	25.6 [7.5] 16.9 [5.0] 1.5	25.9 [7.6] 23.4 [6.9] 1.5	25.4 [7.4] 21.7 [6.4] 1.5	24.8 [7.3] 19.8 [5.8] 1.5
	85 [29.4]	Total BTUH [kW] Sens BTUH [kW] Power	27.6 [8.1] 16.4 [4.8] 1.6	27.1 [7.9] 15.1 [4.4] 1.6	26.4 [7.7] 13.5 [4.0] 1.6	25.9 [7.6] 19.7 [5.8] 1.6	25.4 [7.4] 18.2 [5.3] 1.6	24.8 [7.3] 16.5 [4.8] 1.6	25.1 [7.4] 23.0 [6.7] 1.6	24.6 [7.2] 21.4 [6.3] 1.6	24.0 [7.0] 19.5 [5.7] 1.6
	90 [32.2]	Total BTUH [kW] Sens BTUH [kW] Power	26.8 [7.9] 16.0 [4.7] 1.7	26.2 [7.7] 14.6 [4.3] 1.7	25.6 [7.5] 13.1 [3.8] 1.7	25.1 [7.4] 19.4 [5.7] 1.7	24.6 [7.2] 17.9 [5.2] 1.7	24.0 [7.0] 16.2 [4.7] 1.7	24.2 [7.1] 22.5 [6.6] 1.7	23.7 [6.9] 20.9 [6.1] 1.7	23.1 [6.8] 19.0 [5.6] 1.7
	95 [35]	Total BTUH [kW] Sens BTUH [kW] Power	25.9 [7.6] 15.5 [4.5] 1.9	25.4 [7.4] 14.2 [4.2] 1.8	24.7 [7.2] 12.6 [3.7] 1.8	24.2 [7.1] 18.8 [5.5] 1.9	23.7 [6.9] 17.4 [5.1] 1.8	23.1 [6.8] 15.7 [4.6] 1.8	23.3 [6.8] 22.0 [6.4] 1.9	22.8 [6.7] 20.4 [6.0] 1.8	22.3 [6.5] 18.6 [5.4] 1.8
	100 [37.8]	Total BTUH [kW] Sens BTUH [kW] Power	25.0 [7.3] 15.0 [4.4] 2.0	24.5 [7.2] 13.8 [4.0] 2.0	23.9 [7.0] 12.4 [3.6] 1.9	23.3 [6.8] 18.3 [5.4] 2.0	22.8 [6.7] 16.9 [5.0] 2.0	22.2 [6.5] 15.3 [4.5] 1.9	22.4 [6.6] 21.6 [6.3] 2.0	21.9 [6.4] 20.0 [5.9] 2.0	21.4 [6.3] 18.3 [5.4] 1.9
	105 [40.6]	Total BTUH [kW] Sens BTUH [kW] Power	24.0 [7.0] 14.4 [4.2] 2.1	23.6 [6.9] 13.3 [3.9] 2.1	2.03 [6.7] 11.9 [3.5] 2.1	22.3 [6.5] 17.8 [5.2] 2.1	21.9 [6.4] 16.5 [4.8] 2.1	21.4 [6.3] 15.0 [4.4] 2.1	21.5 [6.3] 21.0 [6.2] 2.1	21.0 [6.2] 19.5 [5.7] 2.1	20.5 [6.0] 17.8 [5.2] 2.1
	110 [43.3]	Total BTUH [kW] Sens BTUH [kW] Power	23.1 [6.8] 14.0 [4.1] 2.3	22.6 [6.6] 12.8 [3.8] 2.2	22.1 [6.5] 11.5 [3.4] 2.2	21.4 [6.3] 17.3 [5.1] 2.3	21.0 [6.2] 16.0 [4.7] 2.2	20.5 [6.0] 14.5 [4.2] 2.2	20.5 [6.0] 20.4 [6.0] 2.3	20.1 [5.9] 19.0 [5.6] 2.2	19.6 [5.7] 17.3 [5.1] 2.2
	115 [46.1]	Total BTUH [kW] Sens BTUH [kW] Power	22.1 [6.5] 13.4 [3.9] 2.4	21.7 [6.4] 12.3 [3.6] 2.4	21.2 [6.2] 11.1 [3.3] 2.3	20.5 [6.0] 16.8 [4.9] 2.4	20.0 [5.9] 15.5 [4.5] 2.4	19.6 [5.7] 14.1 [4.1] 2.4	19.6 [5.7] 19.6 [5.7] 2.4	19.2 [5.6] 18.6 [5.4] 2.4	18.7 [5.5] 17.0 [5.0] 2.4

DR —Depression ratio
dbE —Entering air dry bulb
wbE—Entering air wet bulb

Total —Total capacity x 1000 BTUH
Sens —Sensible capacity x 1000 BTUH
Power —KW input

NOTES: ① When the entering air dry bulb is other than 80°F [27°C], adjust the sensible capacity from the table by adding [1.10 x CFM x (1 – DR) x (dbE – 80)].

[] Designates Metric Conversions

GROSS SYSTEMS PERFORMANCE DATA – RGEAZR030AJT

ENTERING INDOOR AIR @ 80°F [26.7°C] dbE ①											
wbE		71°F [21.7°C]			67°F [19.4°C]			63°F [17.2°C]			
CFM [L/s]		1120 [529]	980 [463]	880 [415]	1120 [529]	980 [463]	880 [415]	1120 [529]	980 [463]	880 [415]	
DR ①		0.11	0.13	0.15	0.11	0.13	0.15	0.11	0.13	0.15	
OUTDOOR DRY BULB TEMPERATURE °F [°C]	75 [23.9]	Total BTUH [kW] Sens BTUH [kW] Power	36.4 [10.7] 23.0 [6.7] 1.8	35.5 [10.4] 20.7 [6.1] 1.7	34.8 [10.2] 19.0 [5.6] 1.7	34.3 [10.0] 26.6 [7.8] 1.8	33.5 [9.8] 24.1 [7.1] 1.7	32.8 [9.6] 22.3 [6.5] 1.7	32.9 [9.6] 30.3 [8.9] 1.8	32.0 [9.4] 27.5 [8.1] 1.7	31.4 [9.2] 25.6 [7.5] 1.7
	80 [26.7]	Total BTUH [kW] Sens BTUH [kW] Power	35.4 [10.4] 22.4 [6.6] 1.9	34.5 [10.1] 20.1 [5.9] 1.8	33.8 [9.9] 18.5 [5.4] 1.8	33.3 [9.8] 26.0 [7.6] 1.9	32.5 [9.5] 23.6 [6.9] 1.8	31.9 [9.3] 21.9 [6.4] 1.8	31.8 [9.3] 29.7 [8.7] 1.9	31.0 [9.1] 27.0 [7.9] 1.8	30.5 [8.9] 25.2 [7.4] 1.8
	85 [29.4]	Total BTUH [kW] Sens BTUH [kW] Power	34.3 [10.0] 21.8 [6.4] 2.0	33.4 [9.8] 19.5 [5.7] 2.0	32.8 [9.6] 18.0 [5.3] 1.9	32.3 [9.5] 25.5 [7.5] 2.0	31.5 [9.2] 23.1 [6.8] 2.0	30.9 [9.1] 21.4 [6.3] 1.9	30.8 [9.0] 29.1 [8.5] 2.0	30.0 [8.8] 26.5 [7.8] 2.0	29.5 [8.6] 24.8 [7.3] 1.9
	90 [32.2]	Total BTUH [kW] Sens BTUH [kW] Power	33.3 [9.8] 21.3 [6.2] 2.1	32.4 [9.5] 19.1 [5.6] 2.1	31.8 [9.3] 17.6 [5.2] 2.1	31.2 [9.1] 24.9 [7.3] 2.1	30.4 [8.9] 22.5 [6.6] 2.1	29.9 [8.8] 21.0 [6.2] 2.1	29.7 [8.7] 28.5 [8.4] 2.1	29.0 [8.5] 26.0 [7.6] 2.1	28.5 [8.4] 24.3 [7.1] 2.1
	95 [35]	Total BTUH [kW] Sens BTUH [kW] Power	32.2 [9.4] 20.7 [6.1] 2.2	31.4 [9.2] 18.6 [5.4] 2.2	30.8 [9.0] 17.1 [5.0] 2.2	30.1 [8.8] 24.3 [7.1] 2.2	29.4 [8.6] 22.1 [6.5] 2.2	28.8 [8.4] 20.5 [6.0] 2.2	28.7 [8.4] 28.1 [8.2] 2.2	27.9 [8.2] 25.5 [7.5] 2.2	27.4 [8.0] 23.8 [7.0] 2.2
	100 [37.8]	Total BTUH [kW] Sens BTUH [kW] Power	31.1 [9.1] 20.2 [5.9] 2.4	30.3 [8.9] 18.1 [5.3] 2.3	29.7 [8.7] 16.7 [4.9] 2.3	29.0 [8.5] 23.8 [7.0] 2.4	28.3 [8.3] 21.6 [6.3] 2.3	27.8 [8.1] 20.1 [5.9] 2.3	27.6 [8.1] 27.4 [8.0] 2.4	26.9 [7.9] 25.0 [7.3] 2.3	26.4 [7.7] 23.3 [6.8] 2.3
	105 [40.6]	Total BTUH [kW] Sens BTUH [kW] Power	29.9 [8.8] 19.5 [5.7] 2.5	29.2 [8.6] 17.6 [5.2] 2.5	28.6 [8.4] 16.2 [4.7] 2.5	27.9 [8.2] 23.3 [6.8] 2.5	27.2 [8.0] 21.1 [6.2] 2.5	26.7 [7.8] 19.6 [5.7] 2.5	26.4 [7.7] 26.4 [7.7] 2.5	25.8 [7.6] 24.6 [7.2] 2.5	25.3 [7.4] 23.0 [6.7] 2.5
	110 [43.3]	Total BTUH [kW] Sens BTUH [kW] Power	28.8 [8.4] 19.1 [5.6] 2.7	28.1 [8.2] 17.2 [5.0] 2.6	27.5 [8.1] 15.8 [4.6] 2.6	26.7 [7.8] 22.6 [6.6] 2.7	26.1 [7.6] 20.6 [6.0] 2.6	25.6 [7.5] 19.1 [5.6] 2.6	25.3 [7.4] 25.3 [7.4] 2.7	24.6 [7.2] 24.0 [7.0] 2.6	24.2 [7.1] 22.5 [6.6] 2.6
	115 [46.1]	Total BTUH [kW] Sens BTUH [kW] Power	27.6 [8.1] 18.5 [5.4] 2.8	26.9 [7.9] 16.6 [4.9] 2.8	26.4 [7.7] 15.3 [4.5] 2.8	25.6 [7.5] 22.2 [6.5] 2.8	24.9 [7.3] 20.1 [5.9] 2.8	24.5 [7.2] 18.8 [5.5] 2.8	24.1 [7.1] 24.1 [7.1] 2.8	23.5 [6.9] 23.5 [6.9] 2.8	23.1 [6.8] 22.0 [6.4] 2.8

DR —Depression ratio
dbE —Entering air dry bulb
wbE —Entering air wet bulb

Total —Total capacity x 1000 BTUH
Sens —Sensible capacity x 1000 BTUH
Power —kW input

NOTES: ① When the entering air dry bulb is other than 80°F [27°C], adjust the sensible capacity from the table by adding [1.10 x CFM x (1 – DR) x (dbE – 80)].

[] Designates Metric Conversions

GROSS SYSTEMS PERFORMANCE DATA—RGEAZR036A(C/D)T

ENTERING INDOOR AIR @ 80°F [26.7°C] dbE ①											
wbE		71°F [21.7°C]			67°F [19.4°C]			63°F [17.2°C]			
CFM [L/s]		1350 [637]	1180 [557]	1050 [496]	1350 [637]	1180 [557]	1050 [496]	1350 [637]	1180 [557]	1050 [496]	
DR ①		0.14	0.16	0.19	0.14	0.16	0.19	0.14	0.16	0.19	
OUTDOOR DRY BULB TEMPERATURE °F [°C]	75 [23.9]	Total BTUH [kW] Sens BTUH [kW] Power	44.2 [13.0] 26.7 [7.8] 2.0	43.1 [12.6] 23.9 [7.0] 2.0	42.2 [12.4] 21.8 [6.4] 2.0	41.2 [12.1] 31.4 [9.2] 2.0	40.2 [11.8] 28.4 [8.3] 2.0	39.4 [11.5] 26.2 [7.7] 2.0	38.8 [11.4] 35.2 [10.3] 2.0	37.9 [11.1] 32.1 [9.4] 2.0	37.1 [10.9] 29.7 [8.7] 2.0
	80 [26.7]	Total BTUH [kW] Sens BTUH [kW] Power	43.0 [12.6] 26.1 [7.6] 2.1	41.9 [12.3] 23.4 [6.9] 2.1	41.1 [12.0] 21.4 [6.3] 2.1	40.0 [11.7] 30.7 [9.0] 2.1	39.0 [11.4] 27.8 [8.1] 2.1	38.2 [11.2] 25.6 [7.5] 2.1	37.6 [11.0] 34.6 [10.1] 2.1	36.7 [10.8] 31.5 [9.2] 2.1	35.9 [10.5] 29.1 [8.5] 2.1
	85 [29.4]	Total BTUH [kW] Sens BTUH [kW] Power	41.7 [12.2] 25.5 [7.5] 2.3	40.7 [11.9] 22.9 [6.7] 2.3	39.9 [11.7] 21.0 [6.2] 2.2	38.7 [11.3] 30.1 [8.8] 2.3	37.8 [11.1] 27.3 [8.0] 2.2	37.0 [10.8] 25.1 [7.4] 2.2	36.4 [10.7] 34.0 [10.0] 2.3	35.4 [10.4] 30.9 [9.1] 2.2	34.7 [10.2] 28.6 [8.4] 2.2
	90 [32.2]	Total BTUH [kW] Sens BTUH [kW] Power	40.4 [11.8] 24.8 [7.3] 2.4	39.4 [11.5] 22.2 [6.5] 2.4	38.6 [11.3] 20.3 [5.9] 2.4	37.4 [11.0] 29.5 [8.6] 2.4	36.5 [10.7] 26.7 [7.8] 2.4	35.7 [10.5] 24.6 [7.2] 2.4	35.1 [10.3] 33.4 [9.8] 2.4	34.2 [10.0] 30.4 [8.9] 2.4	33.5 [9.8] 28.2 [8.3] 2.4
	95 [35]	Total BTUH [kW] Sens BTUH [kW] Power	39.0 [11.4] 24.1 [7.1] 2.6	38.0 [11.1] 21.6 [6.3] 2.5	37.3 [10.9] 19.8 [5.8] 2.5	36.1 [10.6] 28.8 [8.4] 2.6	35.1 [10.3] 26.0 [7.6] 2.5	34.4 [10.1] 24.0 [7.0] 2.5	33.7 [9.9] 32.7 [9.6] 2.6	32.8 [9.6] 29.7 [8.7] 2.5	32.2 [9.4] 27.6 [8.1] 2.5
	100 [37.8]	Total BTUH [kW] Sens BTUH [kW] Power	37.6 [11.0] 23.4 [6.9] 2.7	36.7 [10.8] 21.0 [6.2] 2.7	35.9 [10.5] 19.2 [5.6] 2.7	34.6 [10.1] 28.0 [8.2] 2.7	33.7 [9.9] 25.3 [7.4] 2.7	33.1 [9.7] 23.4 [6.9] 2.7	32.3 [9.5] 32.0 [9.4] 2.7	31.4 [9.2] 29.1 [8.5] 2.7	30.8 [9.0] 27.0 [7.9] 2.7
	105 [40.6]	Total BTUH [kW] Sens BTUH [kW] Power	36.1 [10.6] 22.6 [6.6] 2.9	35.2 [10.3] 20.3 [5.9] 2.9	34.5 [10.1] 18.6 [5.4] 2.8	33.1 [9.7] 27.2 [8.0] 2.9	32.3 [9.5] 24.7 [7.2] 2.9	31.6 [9.3] 22.8 [6.7] 2.8	30.8 [9.0] 30.8 [9.0] 2.9	30.0 [8.8] 28.4 [8.3] 2.9	29.4 [8.6] 26.4 [7.7] 2.8
	110 [43.3]	Total BTUH [kW] Sens BTUH [kW] Power	34.6 [10.1] 21.9 [6.4] 3.1	33.7 [9.9] 19.6 [5.7] 3.0	33.0 [9.7] 17.9 [5.2] 3.0	31.6 [9.3] 26.5 [7.8] 3.1	30.8 [9.0] 24.0 [7.0] 3.0	30.2 [8.8] 22.2 [6.5] 3.0	29.2 [8.6] 29.2 [8.6] 3.1	28.5 [8.4] 27.7 [8.1] 3.0	27.9 [8.2] 25.7 [7.5] 3.0
	115 [46.1]	Total BTUH [kW] Sens BTUH [kW] Power	33.0 [9.7] 21.0 [6.2] 3.3	32.1 [9.4] 18.8 [5.5] 3.2	31.5 [9.2] 17.3 [5.1] 3.2	30.0 [8.8] 25.6 [7.5] 3.3	29.2 [8.6] 23.2 [6.8] 3.2	28.6 [8.4] 21.4 [6.3] 3.2	27.6 [8.1] 27.6 [8.1] 3.2	26.9 [7.9] 26.9 [7.9] 3.2	26.4 [7.7] 25.0 [7.3] 3.2

DR —Depression ratio
dbE —Entering air dry bulb
wbE—Entering air wet bulb

Total —Total capacity x 1000 BTUH
Sens —Sensible capacity x 1000 BTUH
Power —KW input

NOTES: ① When the entering air dry bulb is other than 80°F [27°C], adjust the sensible capacity from the table by adding [1.10 x CFM x (1 - DR) x (dbE - 80)].

[] Designates Metric Conversions

GROSS SYSTEMS PERFORMANCE DATA – RGEAZR036AJT

		ENTERING INDOOR AIR @ 80°F [26.7°C] dbE ①									
wbE		71°F [21.7°C]			67°F [19.4°C]			63°F [17.2°C]			
CFM [L/s]		1350 [637]	1180 [557]	1050 [496]	1350 [637]	1180 [557]	1050 [496]	1350 [637]	1180 [557]	1050 [496]	
DR ①		0.13	0.16	0.18	0.13	0.16	0.18	0.13	0.16	0.18	
OUTDOOR DRY BULB TEMPERATURE °F [°C]	75 [23.9]	Total BTUH [kW] Sens BTUH [kW] Power	44.7 [13.1] 27.0 [7.9] 2.0	43.6 [12.8] 24.2 [7.1] 2.0	42.7 [12.5] 22.1 [6.5] 2.0	41.7 [12.2] 31.7 [9.3] 2.0	40.7 [11.9] 28.7 [8.4] 2.0	39.8 [11.7] 26.4 [7.7] 2.0	39.4 [11.5] 35.6 [10.4] 2.0	38.4 [11.3] 32.4 [9.5] 2.0	37.6 [11.0] 30.0 [8.8] 2.0
	80 [26.7]	Total BTUH [kW] Sens BTUH [kW] Power	43.5 [12.7] 26.5 [7.8] 2.2	42.4 [12.4] 23.7 [6.9] 2.1	41.5 [12.2] 21.6 [6.3] 2.1	40.5 [11.9] 31.1 [9.1] 2.2	39.5 [11.6] 28.1 [8.2] 2.1	38.7 [11.3] 25.9 [7.6] 2.1	38.2 [11.2] 35.0 [10.3] 2.2	37.2 [10.9] 31.8 [9.3] 2.1	36.4 [10.7] 29.4 [8.6] 2.1
	85 [29.4]	Total BTUH [kW] Sens BTUH [kW] Power	42.2 [12.4] 25.8 [7.6] 2.3	41.2 [12.1] 23.2 [6.8] 2.3	40.3 [11.8] 21.2 [6.2] 2.2	39.3 [11.5] 30.5 [8.9] 2.3	38.3 [11.2] 27.6 [8.1] 2.3	37.5 [11.0] 25.4 [7.4] 2.2	36.9 [10.8] 34.4 [10.1] 2.3	36.0 [10.5] 31.3 [9.2] 2.3	35.2 [10.3] 28.9 [8.5] 2.2
	90 [32.2]	Total BTUH [kW] Sens BTUH [kW] Power	40.9 [12.0] 25.1 [7.4] 2.4	39.9 [11.7] 22.5 [6.6] 2.4	39.1 [11.5] 20.6 [6.0] 2.4	37.9 [11.1] 29.8 [8.7] 2.4	37.0 [10.8] 27.0 [7.9] 2.4	36.2 [10.6] 24.9 [7.3] 2.4	35.6 [10.4] 33.7 [9.9] 2.4	34.7 [10.2] 30.7 [9.0] 2.4	34.0 [10.0] 28.5 [8.4] 2.4
	95 [35]	Total BTUH [kW] Sens BTUH [kW] Power	39.6 [11.6] 24.5 [7.2] 2.6	38.5 [11.3] 21.9 [6.4] 2.6	37.8 [11.1] 20.1 [5.9] 2.5	36.6 [10.7] 29.1 [8.5] 2.6	35.6 [10.4] 26.3 [7.7] 2.6	34.9 [10.2] 24.3 [7.1] 2.5	34.2 [10.0] 33.0 [9.7] 2.6	33.3 [9.8] 30.0 [8.8] 2.6	32.7 [9.6] 27.9 [8.2] 2.5
	100 [37.8]	Total BTUH [kW] Sens BTUH [kW] Power	38.1 [11.2] 23.7 [6.9] 2.8	37.2 [10.9] 21.3 [6.2] 2.7	36.4 [10.7] 19.4 [5.7] 2.7	35.1 [10.3] 28.3 [8.3] 2.7	34.2 [10.0] 25.6 [7.5] 2.7	33.6 [9.8] 23.7 [6.9] 2.7	32.8 [9.6] 32.3 [9.5] 2.7	31.9 [9.3] 29.4 [8.6] 2.7	31.3 [9.2] 27.3 [8.0] 2.7
	105 [40.6]	Total BTUH [kW] Sens BTUH [kW] Power	36.6 [10.7] 22.9 [6.7] 2.9	35.7 [10.5] 20.6 [6.0] 2.9	35.0 [10.3] 18.9 [5.5] 2.9	33.7 [9.9] 27.6 [8.1] 2.9	32.8 [9.6] 25.0 [7.3] 2.9	32.1 [9.4] 23.1 [6.8] 2.8	31.3 [9.2] 31.3 [9.2] 2.9	30.5 [8.9] 28.7 [8.4] 2.9	29.9 [8.8] 26.7 [7.8] 2.8
	110 [43.3]	Total BTUH [kW] Sens BTUH [kW] Power	35.1 [10.3] 22.2 [6.5] 3.1	34.2 [10.0] 19.9 [5.8] 3.1	33.5 [9.8] 18.2 [5.3] 3.0	32.1 [9.4] 26.8 [7.9] 3.1	31.3 [9.2] 24.3 [7.1] 3.0	30.7 [9.0] 22.5 [6.6] 3.0	29.7 [8.7] 29.7 [8.7] 3.1	29.0 [8.5] 28.0 [8.2] 3.0	28.4 [8.3] 26.0 [7.6] 3.0
	115 [46.1]	Total BTUH [kW] Sens BTUH [kW] Power	33.5 [9.8] 21.3 [6.2] 3.3	32.6 [9.6] 19.1 [5.6] 3.2	32.0 [9.4] 17.5 [5.1] 3.2	30.5 [8.9] 25.9 [7.6] 3.3	29.7 [8.7] 23.5 [6.9] 3.2	29.1 [8.5] 21.7 [6.4] 3.2	28.1 [8.2] 28.1 [8.2] 3.3	27.4 [8.0] 27.2 [8.0] 3.2	26.9 [7.9] 25.3 [7.4] 3.2

DR —Depression ratio
dbE —Entering air dry bulb
wbE—Entering air wet bulb

Total —Total capacity x 1000 BTUH
Sens —Sensible capacity x 1000 BTUH
Power —KW input

NOTES: ① When the entering air dry bulb is other than 80°F [27°C], adjust the sensible capacity from the table by adding [1.10 x CFM x (1 – DR) x (dbE – 80)].

[] Designates Metric Conversions

GROSS SYSTEMS PERFORMANCE DATA—RGEAZR042ACT

ENTERING INDOOR AIR @ 80°F [26.7°C] dbE ①											
wbE		71°F [21.7°C]			67°F [19.4°C]			63°F [17.2°C]			
CFM [L/s]		1580 [746]	1510 [713]	1220 [576]	1580 [746]	1510 [713]	1220 [576]	1580 [746]	1510 [713]	1220 [576]	
DR ①		0.17	0.17	0.2	0.17	0.17	0.2	0.17	0.17	0.2	
OUTDOOR DRY BULB TEMPERATURE °F [°C]	75 [23.9]	Total BTUH [kW] Sens BTUH [kW] Power	51.4 [15.1] 30.9 [9.1] 2.3	51.0 [14.9] 29.8 [8.7] 2.3	49.2 [14.4] 25.5 [7.5] 2.3	48.3 [14.2] 36.1 [10.6] 2.3	47.9 [14.0] 34.9 [10.2] 2.3	46.2 [13.5] 30.2 [8.8] 2.3	45.8 [13.4] 40.0 [11.7] 2.4	45.4 [13.3] 38.8 [11.4] 2.3	43.8 [12.8] 33.9 [9.9] 2.3
	80 [26.7]	Total BTUH [kW] Sens BTUH [kW] Power	50.0 [14.6] 30.1 [8.8] 2.5	49.6 [14.5] 29.1 [8.5] 2.5	47.8 [14.0] 24.9 [7.3] 2.4	46.9 [13.7] 35.3 [10.3] 2.5	46.5 [13.6] 34.2 [10.0] 2.5	44.9 [13.2] 29.7 [8.7] 2.5	44.4 [13.0] 39.3 [11.5] 2.5	44.0 [12.9] 38.1 [11.2] 2.5	42.5 [12.5] 33.3 [9.8] 2.5
	85 [29.4]	Total BTUH [kW] Sens BTUH [kW] Power	48.5 [14.2] 29.3 [8.6] 2.7	48.1 [14.1] 28.3 [8.3] 2.6	46.4 [13.6] 24.2 [7.1] 2.6	45.4 [13.3] 34.5 [10.1] 2.7	45.0 [13.2] 33.4 [9.8] 2.7	43.5 [12.7] 29.0 [8.5] 2.6	42.9 [12.6] 38.5 [11.3] 2.7	42.6 [12.5] 37.4 [11.0] 2.7	41.1 [12.0] 32.7 [9.6] 2.6
	90 [32.2]	Total BTUH [kW] Sens BTUH [kW] Power	47.0 [13.8] 28.6 [8.4] 2.8	46.6 [13.7] 27.6 [8.1] 2.8	45.0 [13.2] 23.7 [6.9] 2.8	43.9 [12.9] 33.8 [9.9] 2.8	43.6 [12.8] 32.8 [9.6] 2.8	42.0 [12.3] 28.4 [8.3] 2.8	41.4 [12.1] 37.8 [11.1] 2.8	41.1 [12.0] 36.7 [10.8] 2.8	39.6 [11.6] 32.0 [9.4] 2.8
	95 [35]	Total BTUH [kW] Sens BTUH [kW] Power	45.5 [13.3] 27.9 [8.2] 3.0	45.1 [13.2] 26.9 [7.9] 3.0	43.6 [12.8] 23.1 [6.8] 2.9	42.4 [12.4] 33.1 [9.7] 3.0	42.0 [12.3] 32.0 [9.4] 3.0	40.6 [11.9] 27.9 [8.2] 3.0	39.9 [11.7] 37.1 [10.9] 3.0	39.6 [11.6] 36.0 [10.5] 3.0	38.2 [11.2] 31.5 [9.2] 3.0
	100 [37.8]	Total BTUH [kW] Sens BTUH [kW] Power	43.9 [12.9] 27.2 [8.0] 3.2	43.6 [12.8] 26.3 [7.7] 3.2	42.0 [12.3] 22.5 [6.6] 3.1	40.8 [12.0] 32.4 [9.5] 3.2	40.5 [11.9] 31.4 [9.2] 3.2	39.1 [11.5] 27.3 [8.0] 3.1	38.3 [11.2] 36.4 [10.7] 3.2	38.0 [11.1] 35.3 [10.3] 3.2	36.7 [10.8] 31.0 [9.1] 3.1
	105 [40.6]	Total BTUH [kW] Sens BTUH [kW] Power	42.3 [12.4] 26.5 [7.8] 3.4	41.9 [12.3] 25.5 [7.5] 3.4	40.5 [11.9] 21.9 [6.4] 3.3	39.2 [11.5] 31.6 [9.3] 3.4	38.9 [11.4] 30.6 [9.0] 3.4	37.5 [11.0] 26.6 [7.8] 3.3	36.7 [10.8] 35.6 [10.4] 3.4	36.4 [10.7] 34.5 [10.1] 3.4	35.1 [10.3] 30.2 [8.8] 3.3
	110 [43.3]	Total BTUH [kW] Sens BTUH [kW] Power	40.6 [11.9] 25.6 [7.5] 3.6	40.3 [11.8] 24.8 [7.3] 3.5	38.9 [11.4] 21.3 [6.2] 3.5	37.5 [11.0] 30.9 [9.1] 3.6	37.2 [10.9] 29.9 [8.8] 3.6	35.9 [10.5] 26.0 [7.6] 3.5	35.0 [10.3] 34.8 [10.2] 3.6	34.7 [10.2] 33.8 [9.9] 3.6	33.5 [9.8] 29.7 [8.7] 3.5
	115 [46.1]	Total BTUH [kW] Sens BTUH [kW] Power	38.9 [11.4] 24.9 [7.3] 3.8	38.6 [11.3] 24.1 [7.1] 3.7	37.2 [10.9] 20.7 [6.1] 3.7	35.8 [10.5] 30.0 [8.8] 3.8	35.5 [10.4] 29.1 [8.5] 3.8	34.3 [10.0] 25.4 [7.4] 3.7	33.3 [9.8] 33.3 [9.8] 3.8	33.0 [9.7] 33.0 [9.7] 3.8	31.8 [9.3] 28.9 [8.5] 3.7

DR —Depression ratio
dbE —Entering air dry bulb
wbE—Entering air wet bulb

Total —Total capacity x 1000 BTUH
Sens —Sensible capacity x 1000 BTUH
Power —KW input

NOTES: ① When the entering air dry bulb is other than 80°F [27°C], adjust the sensible capacity from the table by adding [1.10 x CFM x (1 – DR) x (dbE – 80)].

[] Designates Metric Conversions

GROSS SYSTEMS PERFORMANCE DATA – RGEAZR042AJT

		ENTERING INDOOR AIR @ 80°F [26.7°C] dbE ①									
wbE		71°F [21.7°C]			67°F [19.4°C]			63°F [17.2°C]			
CFM [L/s]		1580 [746]	1510 [713]	1220 [576]	1580 [746]	1510 [713]	1220 [576]	1580 [746]	1510 [713]	1220 [576]	
DR ①		0.15	0.16	0.19	0.15	0.16	0.19	0.15	0.16	0.19	
OUTDOOR DRY BULB TEMPERATURE °F [°C]	75 [23.9]	Total BTUH [kW] Sens BTUH [kW] Power	51.8 [15.2] 31.3 [9.2] 2.4	51.4 [15.1] 30.2 [8.8] 2.4	49.6 [14.5] 25.9 [7.6] 2.3	48.7 [14.3] 36.5 [10.7] 2.4	48.3 [14.2] 35.3 [10.3] 2.4	46.6 [13.7] 30.6 [9.0] 2.3	46.2 [13.5] 40.5 [11.9] 2.4	45.8 [13.4] 39.2 [11.5] 2.4	44.2 [13.0] 34.2 [10.0] 2.3
	80 [26.7]	Total BTUH [kW] Sens BTUH [kW] Power	50.4 [14.8] 30.5 [8.9] 2.5	50.0 [14.6] 29.5 [8.6] 2.5	48.3 [14.2] 25.3 [7.4] 2.5	47.3 [13.9] 35.8 [10.5] 2.5	46.9 [13.7] 34.6 [10.1] 2.5	45.3 [13.3] 30.0 [8.8] 2.5	44.8 [13.1] 39.7 [11.6] 2.5	44.4 [13.0] 38.5 [11.3] 2.5	42.9 [12.6] 33.7 [9.9] 2.5
	85 [29.4]	Total BTUH [kW] Sens BTUH [kW] Power	49.0 [14.4] 29.8 [8.7] 2.7	48.6 [14.2] 28.8 [8.4] 2.7	46.9 [13.7] 24.7 [7.2] 2.6	45.9 [13.4] 35.0 [10.3] 2.7	45.5 [13.3] 33.9 [9.9] 2.7	43.9 [12.9] 29.4 [8.6] 2.6	43.4 [12.7] 39.0 [11.4] 2.7	43.0 [12.6] 37.8 [11.1] 2.7	41.5 [12.2] 33.0 [9.7] 2.6
	90 [32.2]	Total BTUH [kW] Sens BTUH [kW] Power	47.5 [13.9] 29.1 [8.5] 2.9	47.1 [13.8] 28.1 [8.2] 2.8	45.5 [13.3] 24.1 [7.1] 2.8	44.4 [13.0] 34.3 [10.0] 2.9	44.0 [12.9] 33.2 [9.7] 2.8	42.5 [12.5] 28.9 [8.5] 2.8	41.9 [12.3] 38.3 [11.2] 2.9	41.5 [12.2] 37.1 [10.9] 2.9	40.1 [11.7] 32.5 [9.5] 2.8
	95 [35]	Total BTUH [kW] Sens BTUH [kW] Power	46.0 [13.5] 28.4 [8.3] 3.0	45.6 [13.4] 27.4 [8.0] 3.0	44.0 [12.9] 23.5 [6.9] 3.0	42.8 [12.5] 33.5 [9.8] 3.0	42.5 [12.5] 32.5 [9.5] 3.0	41.0 [12.0] 28.2 [8.3] 3.0	40.3 [11.8] 37.5 [11.0] 3.0	40.0 [11.7] 36.4 [10.7] 3.0	38.6 [11.3] 31.9 [9.3] 3.0
	100 [37.8]	Total BTUH [kW] Sens BTUH [kW] Power	44.4 [13.0] 27.7 [8.1] 3.2	44.0 [12.9] 26.7 [7.8] 3.2	42.5 [12.5] 22.9 [6.7] 3.1	41.3 [12.1] 32.9 [9.6] 3.2	40.9 [12.0] 31.8 [9.3] 3.2	39.5 [11.6] 27.7 [8.1] 3.1	38.8 [11.4] 36.9 [10.8] 3.2	38.4 [11.3] 35.7 [10.5] 3.2	37.1 [10.9] 31.3 [9.2] 3.2
	105 [40.6]	Total BTUH [kW] Sens BTUH [kW] Power	42.7 [12.5] 26.9 [7.9] 3.4	42.4 [12.4] 26.0 [7.6] 3.4	40.9 [12.0] 22.3 [6.5] 3.3	39.6 [11.6] 32.0 [9.4] 3.4	39.3 [11.5] 31.0 [9.1] 3.4	37.9 [11.1] 26.9 [7.9] 3.3	37.1 [10.9] 36.0 [10.5] 3.4	36.8 [10.8] 34.9 [10.2] 3.4	35.5 [10.4] 30.6 [9.0] 3.3
	110 [43.3]	Total BTUH [kW] Sens BTUH [kW] Power	41.1 [12.0] 26.2 [7.7] 3.6	40.7 [11.9] 25.2 [7.4] 3.6	39.3 [11.5] 21.7 [6.4] 3.5	38.0 [11.1] 31.4 [9.2] 3.6	37.6 [11.0] 30.3 [8.9] 3.6	36.3 [10.6] 26.4 [7.7] 3.5	35.4 [10.4] 35.2 [10.3] 3.6	35.2 [10.3] 34.3 [10.0] 3.6	33.9 [9.9] 30.0 [8.8] 3.5
	115 [46.1]	Total BTUH [kW] Sens BTUH [kW] Power	39.4 [11.5] 25.4 [7.4] 3.8	39.0 [11.4] 24.5 [7.2] 3.8	37.7 [11.0] 21.1 [6.2] 3.7	36.2 [10.6] 30.4 [8.9] 3.8	35.9 [10.5] 29.5 [8.6] 3.8	34.7 [10.2] 25.8 [7.6] 3.7	33.7 [9.9] 33.7 [9.9] 3.8	33.4 [9.8] 33.4 [9.8] 3.8	32.3 [9.5] 29.4 [8.6] 3.7

DR —Depression ratio
dbE —Entering air dry bulb
wbE —Entering air wet bulb

Total —Total capacity x 1000 BTUH
Sens —Sensible capacity x 1000 BTUH
Power —kW input

NOTES: ① When the entering air dry bulb is other than 80°F [27°C], adjust the sensible capacity from the table by adding [1.10 x CFM x (1 – DR) x (dbE – 80)].

[] Designates Metric Conversions

GROSS SYSTEMS PERFORMANCE DATA – RGEAZR048A(C/D)T

ENTERING INDOOR AIR @ 80°F [26.7°C] dbE ①											
wbE		71°F [21.7°C]			67°F [19.4°C]			63°F [17.2°C]			
CFM [L/s]		1800 [850]	1730 [817]	1400 [661]	1800 [850]	1730 [817]	1400 [661]	1800 [850]	1730 [817]	1400 [661]	
DR ①		0.19	0.2	0.24	0.19	0.2	0.24	0.19	0.2	0.24	
INDOOR DRY BULB TEMPERATURE °F [°C]	75 [23.9]	Total BTUH [kW] Sens BTUH [kW] Power	58.2 [17.1] 33.0 [9.7] 3.0	57.7 [16.9] 31.9 [9.3] 3.0	55.7 [16.3] 27.2 [8.0] 2.9	54.1 [15.9] 39.3 [11.5] 2.9	53.7 [15.7] 38.2 [11.2] 2.9	51.8 [15.2] 33.1 [9.7] 2.9	50.7 [14.9] 44.0 [12.9] 2.9	50.3 [14.7] 42.8 [12.5] 2.9	48.6 [14.2] 37.4 [11.0] 2.9
	80 [26.7]	Total BTUH [kW] Sens BTUH [kW] Power	56.9 [16.7] 32.5 [9.5] 3.1	56.5 [16.6] 31.5 [9.2] 3.1	54.5 [16.0] 26.9 [7.9] 3.1	52.8 [15.5] 38.9 [11.4] 3.1	52.4 [15.4] 37.8 [11.1] 3.1	50.6 [14.8] 32.8 [9.6] 3.0	49.4 [14.5] 43.5 [12.7] 3.0	49.1 [14.4] 42.4 [12.4] 3.0	47.4 [13.9] 37.1 [10.9] 3.0
	85 [29.4]	Total BTUH [kW] Sens BTUH [kW] Power	55.5 [16.3] 32.0 [9.4] 3.3	55.1 [16.1] 31.0 [9.1] 3.3	53.2 [15.6] 26.5 [7.8] 3.2	51.4 [15.1] 38.4 [11.3] 3.2	51.0 [14.9] 37.3 [10.9] 3.2	49.3 [14.4] 32.4 [9.5] 3.2	48.1 [14.1] 43.1 [12.6] 3.2	47.7 [14.0] 41.9 [12.3] 3.2	46.1 [13.5] 36.7 [10.8] 3.1
	90 [32.2]	Total BTUH [kW] Sens BTUH [kW] Power	54.0 [15.8] 31.4 [9.2] 3.4	53.6 [15.7] 30.4 [8.9] 3.4	51.8 [15.2] 26.1 [7.6] 3.3	49.9 [14.6] 37.7 [11.0] 3.4	49.5 [14.5] 36.6 [10.7] 3.4	47.8 [14.0] 31.8 [9.3] 3.3	46.6 [13.7] 42.5 [12.5] 3.3	46.2 [13.5] 41.3 [12.1] 3.3	44.6 [13.1] 36.2 [10.6] 3.3
	95 [35]	Total BTUH [kW] Sens BTUH [kW] Power	52.4 [15.4] 30.6 [9.0] 3.6	52.0 [15.2] 29.6 [8.7] 3.6	50.2 [14.7] 25.3 [7.4] 3.5	48.3 [14.2] 37.0 [10.8] 3.5	48.0 [14.1] 36.0 [10.5] 3.5	46.3 [13.6] 31.2 [9.1] 3.5	45.0 [13.2] 41.7 [12.2] 3.5	44.6 [13.1] 40.5 [11.9] 3.5	43.1 [12.6] 35.5 [10.4] 3.4
	100 [37.8]	Total BTUH [kW] Sens BTUH [kW] Power	50.7 [14.9] 29.8 [8.7] 3.8	50.3 [14.7] 28.8 [8.4] 3.7	48.6 [14.2] 24.7 [7.2] 3.7	46.6 [13.7] 36.1 [10.6] 3.7	46.3 [13.6] 35.1 [10.3] 3.7	44.7 [13.1] 30.5 [8.9] 3.7	43.3 [12.7] 40.9 [12.0] 3.7	43.0 [12.6] 39.8 [11.7] 3.7	41.5 [12.2] 34.9 [10.2] 3.6
	105 [40.6]	Total BTUH [kW] Sens BTUH [kW] Power	48.9 [14.3] 28.7 [8.4] 3.9	48.6 [14.2] 27.9 [8.2] 3.9	46.9 [13.7] 23.9 [7.0] 3.9	44.8 [13.1] 35.2 [10.3] 3.9	44.5 [13.0] 34.2 [10.0] 3.9	42.9 [12.6] 29.7 [8.7] 3.8	41.5 [12.2] 39.8 [11.7] 3.9	41.2 [12.1] 38.8 [11.4] 3.9	39.7 [11.6] 34.0 [10.0] 3.8
	110 [43.3]	Total BTUH [kW] Sens BTUH [kW] Power	47.0 [13.8] 27.7 [8.1] 4.1	46.7 [13.7] 26.9 [7.9] 4.1	45.0 [13.2] 23.0 [6.7] 4.1	42.9 [12.6] 34.0 [10.0] 4.1	42.6 [12.5] 33.1 [9.7] 4.1	41.1 [12.0] 28.8 [8.4] 4	39.6 [11.6] 38.8 [11.4] 4.1	39.3 [11.5] 37.8 [11.1] 4.1	37.9 [11.1] 33.2 [9.7] 4.0
	115 [46.1]	Total BTUH [kW] Sens BTUH [kW] Power	45.0 [13.2] 26.5 [7.8] 4.4	44.7 [13.1] 25.7 [7.5] 4.3	43.1 [12.6] 22.0 [6.4] 4.3	40.9 [12.0] 32.8 [9.6] 4.3	40.6 [11.9] 31.9 [9.3] 4.3	39.2 [11.5] 27.8 [8.1] 4.2	37.5 [11.0] 37.5 [11.0] 4.3	37.3 [10.9] 36.6 [10.7] 4.3	36.0 [10.5] 32.2 [9.4] 4.2

DR —Depression ratio
dbE —Entering air dry bulb
wbE—Entering air wet bulb

Total —Total capacity x 1000 BTUH
Sens —Sensible capacity x 1000 BTUH
Power —KW input

NOTES: ① When the entering air dry bulb is other than 80°F [27°C], adjust the sensible capacity from the table by adding [1.10 x CFM x (1 – DR) x (dbE – 80)].

[] Designates Metric Conversions

GROSS SYSTEMS PERFORMANCE DATA – RGEAZR048AJT

		ENTERING INDOOR AIR @ 80°F [26.7°C] dbE ①									
wbE		71°F [21.7°C]			67°F [19.4°C]			63°F [17.2°C]			
CFM [L/s]		1800 [850]	1730 [817]	1400 [661]	1800 [850]	1730 [817]	1400 [661]	1800 [850]	1730 [817]	1400 [661]	
DR ①		0.18	0.19	0.22	0.18	0.19	0.22	0.18	0.19	0.22	
OUTDOOR DRY BULB TEMPERATURE °F [°C]	75 [23.9]	Total BTUH [kW] Sens BTUH [kW] Power	58.7 [17.2] 33.5 [9.8] 3.0	58.3 [17.1] 32.5 [9.5] 3.0	56.3 [16.5] 27.8 [8.1] 3.0	54.6 [16.0] 39.8 [11.7] 3.0	54.2 [15.9] 38.7 [11.3] 3.0	52.4 [15.4] 33.6 [9.8] 2.9	51.3 [15.0] 44.6 [13.1] 3.0	50.9 [14.9] 43.4 [12.7] 3.0	49.2 [14.4] 38.0 [11.1] 2.9
	80 [26.7]	Total BTUH [kW] Sens BTUH [kW] Power	57.5 [16.8] 33.1 [9.7] 3.2	57.0 [16.7] 32.0 [9.4] 3.2	55.1 [16.1] 27.4 [8.0] 3.1	53.4 [15.6] 39.5 [11.6] 3.1	53.0 [15.5] 38.4 [11.3] 3.1	51.1 [15.0] 33.3 [9.8] 3.1	50.0 [14.6] 44.1 [12.9] 3.1	49.6 [14.5] 42.9 [12.6] 3.1	47.9 [14.0] 37.5 [11.0] 3.0
	85 [29.4]	Total BTUH [kW] Sens BTUH [kW] Power	56.1 [16.4] 32.6 [9.6] 3.3	55.7 [16.3] 31.6 [9.3] 3.3	53.7 [15.7] 2.07 [7.9] 3.2	52.0 [15.2] 39.0 [11.4] 3.3	51.6 [15.1] 37.9 [11.1] 3.3	49.8 [14.6] 32.9 [9.6] 3.2	48.6 [14.2] 43.6 [12.8] 3.2	48.3 [14.2] 42.5 [12.5] 3.2	46.6 [13.7] 37.2 [10.9] 3.2
	90 [32.2]	Total BTUH [kW] Sens BTUH [kW] Power	54.6 [16.0] 32.0 [9.4] 3.5	54.2 [15.9] 31.0 [9.1] 3.5	52.3 [15.3] 26.5 [7.8] 3.4	50.5 [14.8] 38.3 [11.2] 3.4	50.1 [14.7] 37.2 [10.9] 3.4	48.4 [14.2] 32.3 [9.5] 3.4	47.1 [13.8] 43.0 [12.6] 3.4	46.8 [13.7] 41.9 [12.3] 3.4	45.2 [13.2] 36.7 [10.8] 3.3
	95 [35]	Total BTUH [kW] Sens BTUH [kW] Power	53.0 [15.5] 31.2 [9.1] 3.6	52.6 [15.4] 30.2 [8.8] 3.6	50.8 [14.9] 25.9 [7.6] 3.6	48.9 [14.3] 37.6 [11.0] 3.6	48.5 [14.2] 36.5 [10.7] 3.6	46.8 [13.7] 31.7 [9.3] 3.5	45.5 [13.3] 42.2 [12.4] 3.6	45.2 [13.2] 41.1 [12.0] 3.6	43.6 [12.8] 36.0 [10.5] 3.5
	100 [37.8]	Total BTUH [kW] Sens BTUH [kW] Power	51.3 [15.0] 30.4 [8.9] 3.8	50.9 [14.9] 29.4 [8.6] 3.8	49.2 [14.4] 25.2 [7.4] 3.7	47.2 [13.8] 36.7 [10.8] 3.8	46.8 [13.7] 35.6 [10.4] 3.8	45.2 [13.2] 31.0 [9.1] 3.7	43.8 [12.8] 41.4 [12.1] 3.7	43.5 [12.7] 40.3 [11.8] 3.7	42.0 [12.3] 35.3 [10.3] 3.7
	105 [40.6]	Total BTUH [kW] Sens BTUH [kW] Power	49.5 [14.5] 29.3 [8.6] 4.0	49.1 [14.4] 28.4 [8.3] 4.0	47.4 [13.9] 24.3 [7.1] 3.9	45.4 [13.3] 35.8 [10.5] 4.0	45.0 [13.2] 34.7 [10.2] 3.9	43.5 [12.7] 30.2 [8.8] 3.9	42.0 [12.3] 40.3 [11.8] 3.9	41.7 [12.2] 39.3 [11.5] 3.9	40.3 [11.8] 34.5 [10.1] 3.8
	110 [43.3]	Total BTUH [kW] Sens BTUH [kW] Power	47.6 [13.9] 28.3 [8.3] 4.2	47.2 [13.8] 27.4 [8.0] 4.2	45.6 [13.4] 23.5 [6.9] 4.1	43.5 [12.7] 34.6 [10.1] 4.2	43.2 [12.7] 33.7 [9.9] 4.1	41.7 [12.2] 29.3 [8.6] 4.1	40.1 [11.7] 39.3 [11.5] 4.1	39.8 [11.7] 38.3 [11.2] 4.1	38.5 [11.3] 33.7 [9.9] 4
	115 [46.1]	Total BTUH [kW] Sens BTUH [kW] Power	45.6 [13.4] 27.1 [7.9] 4.4	45.2 [13.2] 26.2 [7.7] 4.4	43.7 [12.8] 22.5 [6.6] 4.3	41.5 [12.2] 33.4 [9.8] 4.4	41.1 [12.0] 32.4 [9.5] 4.4	39.7 [11.6] 28.2 [8.3] 4.3	38.1 [11.2] 38.1 [11.2] 4.3	37.8 [11.1] 37.1 [10.9] 4.3	36.5 [10.7] 32.6 [9.6] 4.2

DR —Depression ratio
dbE —Entering air dry bulb
wbE—Entering air wet bulb

Total —Total capacity x 1000 BTUH
Sens —Sensible capacity x 1000 BTUH
Power —KW input

NOTES: ① When the entering air dry bulb is other than 80°F [27°C], adjust the sensible capacity from the table by adding [1.10 x CFM x (1 – DR) x (dbE – 80)].

[] Designates Metric Conversions

GROSS SYSTEMS PERFORMANCE DATA—RGEAZR060A(C/D)T

ENTERING INDOOR AIR @ 80°F [26.7°C] dbE ①											
wbE		71°F [21.7°C]			67°F [19.4°C]			63°F [17.2°C]			
CFM [L/s]		2100 [991]	1700 [802]	1600 [755]	2100 [991]	1700 [802]	1600 [755]	2100 [991]	1700 [802]	1600 [755]	
DR ①		0.03	0.09	0.1	0.03	0.09	0.1	0.03	0.09	0.1	
INDOOR DRY BULB TEMPERATURE °F [°C]	75 [23.9]	Total BTUH [kW] Sens BTUH [kW] Power	73.8 [21.6] 47.1 [13.8] 3.8	70.7 [20.7] 39.3 [11.5] 3.7	70.0 [20.5] 37.5 [11.0] 3.7	68.8 [20.2] 54.5 [16.0] 3.7	66.0 [19.3] 46.3 [13.6] 3.6	65.2 [19.1] 44.3 [13.0] 3.6	64.4 [18.9] 60.9 [17.8] 3.6	61.7 [18.1] 52.2 [15.3] 3.6	61.1 [17.9] 50.2 [14.7] 3.6
	80 [26.7]	Total BTUH [kW] Sens BTUH [kW] Power	71.9 [21.1] 46.1 [13.5] 3.9	68.9 [20.2] 38.5 [11.3] 3.8	68.2 [20.0] 36.8 [10.8] 3.8	66.9 [19.6] 53.4 [15.6] 3.9	64.1 [18.8] 45.3 [13.3] 3.8	63.4 [18.6] 43.4 [12.7] 3.8	62.5 [18.3] 59.9 [17.6] 3.8	59.9 [17.6] 51.4 [15.1] 3.7	59.3 [17.4] 49.4 [14.5] 3.7
	85 [29.4]	Total BTUH [kW] Sens BTUH [kW] Power	69.9 [20.5] 44.8 [13.1] 4.1	67.0 [19.6] 37.5 [11.0] 4.0	66.3 [19.4] 35.8 [10.5] 4.0	64.9 [19.0] 52.3 [15.3] 4.1	62.2 [18.2] 44.4 [13.0] 4.0	61.5 [18.0] 42.5 [12.5] 4.0	60.5 [17.7] 58.7 [17.2] 4.0	58.0 [17.0] 50.4 [14.8] 3.9	57.4 [16.8] 48.4 [14.2] 3.9
	90 [32.2]	Total BTUH [kW] Sens BTUH [kW] Power	67.8 [19.9] 43.5 [12.7] 4.3	65.0 [19.0] 36.4 [10.7] 4.2	64.3 [18.8] 34.7 [10.2] 4.2	62.8 [18.4] 50.9 [14.9] 4.3	60.2 [17.6] 43.3 [12.7] 4.2	59.6 [17.5] 41.5 [12.2] 4.2	58.4 [17.1] 57.4 [16.8] 4.2	56.0 [16.4] 49.3 [14.4] 4.1	55.4 [16.2] 47.4 [13.9] 4.1
	95 [35]	Total BTUH [kW] Sens BTUH [kW] Power	65.6 [19.2] 42.1 [12.3] 4.5	62.9 [18.4] 35.2 [10.3] 4.4	62.3 [18.3] 33.7 [9.9] 4.4	60.6 [17.8] 49.5 [14.5] 4.5	58.1 [17.0] 42.1 [12.3] 4.4	57.5 [16.8] 40.4 [11.8] 4.4	56.2 [16.5] 55.9 [16.4] 4.4	53.9 [15.8] 48.1 [14.1] 4.3	53.3 [15.6] 46.2 [13.5] 4.3
	100 [37.8]	Total BTUH [kW] Sens BTUH [kW] Power	63.4 [18.6] 40.7 [11.9] 4.8	60.8 [17.8] 34.1 [10.0] 4.7	60.1 [17.6] 32.5 [9.5] 4.6	58.4 [17.1] 48.1 [14.1] 4.7	56.0 [16.4] 40.9 [12.0] 4.6	55.4 [16.2] 39.2 [11.5] 4.6	54.0 [15.8] 54.0 [15.8] 4.7	51.8 [15.2] 47.0 [13.8] 4.6	51.2 [15.0] 45.1 [13.2] 4.5
	105 [40.6]	Total BTUH [kW] Sens BTUH [kW] Power	61.0 [17.9] 39.1 [11.5] 5.0	58.5 [17.1] 32.7 [9.6] 4.9	57.9 [17.0] 31.2 [9.1] 4.9	56.1 [16.4] 46.5 [13.6] 5.0	53.8 [15.8] 39.6 [11.6] 4.9	53.2 [15.6] 37.9 [11.1] 4.8	51.7 [15.1] 51.7 [15.1] 4.9	49.5 [14.5] 45.6 [13.4] 4.8	49.0 [14.4] 43.9 [12.9] 4.8
	110 [43.3]	Total BTUH [kW] Sens BTUH [kW] Power	58.6 [17.2] 37.4 [11.0] 5.3	56.2 [16.5] 31.3 [9.2] 5.2	55.6 [16.3] 29.9 [8.8] 5.1	53.6 [15.7] 44.7 [13.1] 5.2	51.4 [15.1] 38.1 [11.2] 5.1	50.9 [14.9] 36.6 [10.7] 5.1	49.2 [14.4] 49.2 [14.4] 5.2	47.2 [13.8] 44.2 [13.0] 5.1	46.7 [13.7] 42.5 [12.5] 5.0
	115 [46.1]	Total BTUH [kW] Sens BTUH [kW] Power	56.1 [16.4] 35.6 [10.4] 5.5	53.8 [15.8] 29.8 [8.7] 5.4	53.3 [15.6] 28.5 [8.4] 5.4	51.1 [15.0] 42.9 [12.6] 5.5	49.0 [14.4] 36.6 [10.7] 5.4	48.5 [14.2] 35.1 [10.3] 5.3	46.7 [13.7] 46.7 [13.7] 5.4	44.8 [13.1] 42.7 [12.5] 5.3	44.3 [13.0] 41.0 [12.0] 5.3

DR —Depression ratio
dbE —Entering air dry bulb
wbE—Entering air wet bulb

Total —Total capacity x 1000 BTUH
Sens —Sensible capacity x 1000 BTUH
Power —KW input

NOTES: ① When the entering air dry bulb is other than 80°F [27°C], adjust the sensible capacity from the table by adding [1.10 x CFM x (1 - DR) x (dbE - 80)].

[] Designates Metric Conversions

GROSS SYSTEMS PERFORMANCE DATA – RGEAZR060AJT

ENTERING INDOOR AIR @ 80°F [26.7°C] dbE ①											
wbE		71°F [21.7°C]			67°F [19.4°C]			63°F [17.2°C]			
CFM [L/s]		2100 [991]	1700 [802]	1600 [755]	2100 [991]	1700 [802]	1600 [755]	2100 [991]	1700 [802]	1600 [755]	
DR ①		0.02	0.08	0.09	0.02	0.08	0.09	0.02	0.08	0.09	
OUTDOOR DRY BULB TEMPERATURE °F [°C]	75 [23.9]	Total BTUH [kW] Sens BTUH [kW] Power	74.2 [21.7] 47.5 [13.9] 3.8	71.2 [20.9] 39.8 [11.7] 3.7	70.4 [20.6] 37.9 [11.1] 3.7	69.2 [20.3] 54.9 [16.1] 3.7	66.4 [19.5] 46.7 [13.7] 3.6	65.7 [19.2] 44.7 [13.1] 3.6	64.8 [19.0] 61.4 [18.0] 3.7	62.2 [18.2] 52.7 [15.4] 3.6	61.5 [18.0] 50.6 [14.8] 3.6
	80 [26.7]	Total BTUH [kW] Sens BTUH [kW] Power	72.3 [21.2] 46.5 [13.6] 3.9	69.4 [20.3] 39.0 [11.4] 3.9	68.6 [20.1] 37.2 [10.9] 3.8	67.3 [19.7] 53.8 [15.8] 3.9	64.6 [18.9] 45.8 [13.4] 3.8	63.9 [18.7] 43.9 [12.9] 3.8	62.9 [18.4] 60.4 [17.7] 3.8	60.3 [17.7] 51.8 [15.2] 3.8	59.7 [17.5] 49.8 [14.6] 3.7
	85 [29.4]	Total BTUH [kW] Sens BTUH [kW] Power	70.3 [20.6] 45.3 [13.3] 4.1	67.4 [19.7] 37.9 [11.1] 4.0	66.7 [19.5] 36.2 [10.6] 4.0	65.3 [19.1] 52.7 [15.4] 4.1	62.7 [18.4] 44.9 [13.2] 4.0	62.0 [18.2] 43.0 [12.6] 4.0	60.9 [17.8] 59.2 [17.3] 4.0	58.4 [17.1] 50.8 [14.9] 3.9	57.8 [16.9] 48.8 [14.3] 3.9
	90 [32.2]	Total BTUH [kW] Sens BTUH [kW] Power	68.2 [20.0] 43.9 [12.9] 4.3	65.4 [19.2] 36.8 [10.8] 4.2	64.7 [19.0] 35.1 [10.3] 4.2	63.3 [18.5] 51.5 [15.1] 4.3	60.7 [17.8] 43.8 [12.8] 4.2	60.0 [17.6] 41.9 [12.3] 4.2	58.9 [17.3] 57.9 [17.0] 4.2	56.4 [16.5] 49.7 [14.6] 4.1	55.8 [16.3] 47.8 [14.0] 4.1
	95 [35]	Total BTUH [kW] Sens BTUH [kW] Power	66.1 [19.4] 42.6 [12.5] 4.5	63.4 [18.6] 35.7 [10.5] 4.5	62.7 [18.4] 34.0 [10.0] 4.4	61.1 [17.9] 50.1 [14.7] 4.5	58.6 [17.2] 42.6 [12.5] 4.4	58.0 [17.0] 40.8 [12.0] 4.4	56.7 [16.6] 56.5 [16.6] 4.4	54.4 [15.9] 48.6 [14.2] 4.4	53.8 [15.8] 46.7 [13.7] 4.3
	100 [37.8]	Total BTUH [kW] Sens BTUH [kW] Power	63.8 [18.7] 41.2 [12.1] 4.8	61.2 [17.9] 34.5 [10.1] 4.7	60.6 [17.8] 33.0 [9.7] 4.7	58.9 [17.3] 48.6 [14.2] 4.7	56.4 [16.5] 41.3 [12.1] 4.6	55.8 [16.3] 39.6 [11.6] 4.6	54.5 [16.0] 54.5 [16.0] 4.7	52.2 [15.3] 47.4 [13.9] 4.6	51.7 [15.1] 45.6 [13.4] 4.6
	105 [40.6]	Total BTUH [kW] Sens BTUH [kW] Power	61.5 [18.0] 39.6 [11.6] 5.0	59.0 [17.3] 33.2 [9.7] 4.9	58.4 [17.1] 31.7 [9.3] 4.9	56.5 [16.6] 46.9 [13.7] 5.0	54.2 [15.9] 40.0 [11.7] 4.9	53.6 [15.7] 38.3 [11.2] 4.8	52.1 [15.3] 52.1 [15.3] 4.9	50.0 [14.6] 46.1 [13.5] 4.8	49.4 [14.5] 44.3 [13.0] 4.8
	110 [43.3]	Total BTUH [kW] Sens BTUH [kW] Power	59.1 [17.3] 38.0 [11.1] 5.3	56.7 [16.6] 31.8 [9.3] 5.2	56.1 [16.4] 30.3 [8.9] 5.1	54.1 [15.9] 45.3 [13.3] 5.2	51.9 [15.2] 38.6 [11.3] 5.1	51.3 [15.0] 37.0 [10.8] 5.1	49.7 [14.6] 49.7 [14.6] 5.2	47.7 [14.0] 44.7 [13.1] 5.1	47.2 [13.8] 43.0 [12.6] 5.0
	115 [46.1]	Total BTUH [kW] Sens BTUH [kW] Power	56.6 [16.6] 36.2 [10.6] 5.6	54.3 [15.9] 30.3 [8.9] 5.4	53.7 [15.7] 28.9 [8.5] 5.4	51.6 [15.1] 43.5 [12.7] 5.5	49.5 [14.5] 37.1 [10.9] 5.4	49.0 [14.4] 35.6 [10.4] 5.4	47.2 [13.8] 47.2 [13.8] 5.4	45.3 [13.3] 43.2 [12.7] 5.3	44.8 [13.1] 41.5 [12.2] 5.3

DR —Depression ratio
dbE —Entering air dry bulb
wbE—Entering air wet bulb

Total —Total capacity x 1000 BTUH
Sens —Sensible capacity x 1000 BTUH
Power—KW input

NOTES: ① When the entering air dry bulb is other than 80°F [27°C], adjust the sensible capacity from the table by adding [1.10 x CFM x (1 – DR) x (dbE – 80)].

[] Designates Metric Conversions

INDOOR AIRFLOW PERFORMANCE RGEAZR (208/230V, 1-PHASE) CONSTANT TORQUE MOTOR (Con't.)

Nominal Cooling Capacity Tons [kW]	Motor Speed from Factory		Recommended Speed Tap for Field Installed Heater Kit	Manufacturer Recommended Cooling Airflow (Min/Max)	Blower Size, Motor HP [W] & # of Speeds	Motor Tap - Usage	External Static Pressure - Inches W.C. [kPa]										
	Cool	Heat					0.1 [.02]	0.2 [.05]	0.3 [.07]	0.4 [.10]	0.5 [.12]	0.6 [.15]	0.7 [.17]	0.8 [.20]	0.9 [.22]	1.0 [.25]	
3.0 [10.55]	Tap 3			1050 CFM / 1350 CFM	12x9T Blower 1 HP [746] 5 Speed (Constant Torque)	Tap 1 - FAN	CFM	977	915	833	764	700	557	475	398	338	295
							RPM	609	649	709	766	806	846	880	901	911	934
							Watts	115	118	130	141	147	154	159	164	165	167
						Tap 2 - 60K	CFM	1058	1020	963	885	831	765	682	586	526	445
							RPM	646	680	725	795	832	875	912	953	970	988
							Watts	140	145	156	170	176	185	191	201	204	207
						Tap 2 - 80K	CFM	1347	1314	1279	1245	1198	1128	1083	1038	985	923
							RPM	773	809	837	870	907	955	989	1037	1069	1107
							Watts	255	270	276	287	297	313	320	335	344	356
							CFM	1442	1417	1386	1349	1312	1252	1195	1143	1086	1044
	RPM	828	857	885	918	946	988	1028	1063	1094	1123						
	Watts	313	323	332	343	353	367	380	390	402	412						
	CFM	1336	1297	1264	1225	1188	1105	1043	984	931	867						
	RPM	771	804	837	866	897	952	988	1022	1056	1083						
	Watts	249	259	271	278	285	300	315	319	328	337						
	CFM	1486	1449	1418	1386	1351	1311	1240	1189	1135	1098						
	RPM	840	874	902	930	958	988	1036	1069	1100	1130						
	Watts	332	344	353	364	374	384	398	412	422	433						
	CFM	1517	1493	1465	1429	1401	1364	1294	1249	1203	1148						
	RPM	868	893	922	947	973	1003	1052	1088	1113	1145						
	Watts	362	371	380	391	400	411	430	443	453	462						

NOTES: 1. FOR CONSTANT TORQUE MOTORS: USE MOTOR TAPS 3-5 TO ACHIEVE RATED AIRFLOW AT AHRI MINIMUM EXTERNAL STATIC PRESSURE.

(a) Use * marked tap for AHRI 210/240-2023

(b) Use ** marked tap for AHRI 210/240-2017

2. GRAYED OUT PORTIONS NOT RECOMMENDED FOR USE IN FIELD.

DOWN DISCHARGE PRESSURE DROP (ADD TO EXTERNAL STATIC PRESSURE)				
CFM [L/s]	800 [378]	1000 [472]	1200 [566]	2000 [944]
Pressure Drop—Includes W.C. [kPa]	.02 [.005]	.05 [.012]	.07 [.017]	.17 [.042]

[] Designates Metric Conversions

INDOOR AIRFLOW PERFORMANCE RGEAZR (208/230V, 1-PHASE) CONSTANT TORQUE MOTOR (Con't.)

Nominal Cooling Capacity Tons [kW]	Motor Speed from Factory		Recommended Speed Tap for Field Installed Heater Kit	Manufacturer Recommended Cooling Airflow (Min/Max)	Blower Size, Motor HP [W] & # of Speeds	Motor Tap - Usage	External Static Pressure - Inches W.C. [kPa] (Side Discharge-Dry Coil)									
	Cool	Heat					0.1 [0.02]	0.2 [0.05]	0.3 [0.07]	0.4 [0.10]	0.5 [0.12]	0.6 [0.15]	0.7 [0.17]	0.8 [0.20]	0.9 [0.22]	1.0 [0.25]
							CFM	RPM	Watts	CFM	RPM	Watts	CFM	RPM	Watts	CFM
3.5 [12.31]	Tap 3	Tap 2	80,000 [23.45]	1225 CFM / 1575 CFM	12x9T Blower 3/4 HP [559] 5 Speed (Constant Torque)	Tap 1 - FAN	992	903	804	723	629	525	455	375	333	296
							589	622	680	725	761	814	837	855	883	915
							106	110	119	127	132	141	145	146	152	157
							1440	1390	1354	1309	1257	1194	1136	1040	987	923
							767	801	828	861	896	937	973	1021	1047	1073
							266	276	283	292	304	317	327	342	350	360
							1465	1414	1370	1334	1290	1228	1164	1100	1032	978
							775	810	841	869	899	938	974	1011	1048	1074
							277	287	297	305	314	327	337	349	362	371
							1557	1517	1475	1436	1398	1352	1306	1245	1178	1119
4.0 [14.07]	Tap 3 - Low Stage Tap 4 - High Stage	Tap 2	80,000 [23.45]	1400 CFM / 1800 CFM	12x9R Blower 1 HP [746] 5 Speed (Constant Torque)	Tap 2 - 100K Tap 3 - Low Stage Cool Tap 4 - High Stage Cool * Med Static Tap 5 - High Static Cool *	519	530	540	562	562	577	586	583	570	531
							1013	866	781	695	561	493	427	371	322	268
							116	104	108	116	120	125	130	134	140	144
							590	597	644	689	720	755	785	816	847	875
							1349	1306	1264	1220	1169	1108	1046	990	938	883
							733	766	791	820	848	882	913	937	964	999
							232	241	248	256	264	273	281	288	296	306
							1416	1383	1340	1293	1253	1201	1141	1080	1015	977
							764	790	819	847	873	902	936	963	990	1012
							266	273	282	291	298	307	317	324	333	340
1354	1316	1273	1229	1179	1121	1062	997	954	891							
745	773	802	826	856	888	919	945	968	1007							
239	247	255	260	270	280	287	295	301	312							
1769	1734	1706	1665	1634	1595	1560	1526	1481	1444							
903	931	953	980	999	1028	1048	1071	1094	1117							
468	481	490	500	511	524	532	543	554	566							
1966	1938	1916	1882	1855	1822	1803	1778	1739	1700							
1003	1027	1047	1070	1091	1115	1128	1150	1172	1195							
657	670	682	695	707	721	730	742	756	769							

[*] Designates Metric Conversions

INDOOR AIRFLOW PERFORMANCE RGEAZR (208/230V, 1-PHASE) CONSTANT TORQUE MOTOR (Con't.)

Nominal Cooling Capacity Tons [kW]	Motor Speed from Factory		Recommended Speed Tap for Field Installed Heater Kit	Manufacturer Recommended Cooling Airflow (Min/Max)	Blower Size, Motor HP [W] & # of Speeds	Motor Tap - Usage	External Static Pressure - Inches W.C. [kPa]										
	Cool	Heat					0.1 [.02]	0.2 [.05]	0.3 [.07]	0.4 [.10]	0.5 [.12]	0.6 [.15]	0.7 [.17]	0.8 [.20]	0.9 [.22]	1.0 [.25]	
5.0 [17.59]		Tap 3 - Low Stage		1750 CFM / 2250 CFM	12x9R Blower 1 HP [746] 5 Speed (Constant Torque)	Tap 1 - FAN	CFM	999	856	786	694	575	502	428	379	331	280
							RPM	590	599	640	681	715	752	789	814	847	871
							Watts	116	104	108	114	120	125	131	135	140	145
		Tap 2	80,000 [23.45]			Tap 2 - 80K	CFM	1373	1328	1291	1244	1197	1144	1088	1032	978	931
							RPM	742	773	804	833	862	895	926	953	977	1001
							Watts	247	255	264	273	281	291	300	308	315	323
		Tap 3 - Low Stage				Tap 2 - 100K	CFM	1438	1392	1356	1318	1273	1223	1172	1115	1056	1009
							RPM	772	801	832	856	883	915	945	975	1000	1026
		Tap 4 - High Stage				Tap 3 - Low Stage Cool	Watts	278	288	297	306	313	324	334	343	351	359
							CFM	1419	1381	1350	1301	1256	1207	1140	1086	1035	977
						RPM	763	791	817	847	876	909	943	970	995	1020	
						Watts	268	277	285	295	304	314	323	332	340	348	
						CFM	1938	1904	1873	1841	1813	1811	1754	1726	1694	1661	
						RPM	976	1002	1019	1043	1063	1065	1107	1130	1159	1180	
						Watts	622	638	645	657	669	670	693	707	725	737	
						CFM	2138	2106	2084	2050	2025	1990	1963	1943	1914	1891	
						RPM	1057	1075	1094	1117	1134	1162	1186	1206	1229	1245	
						Watts	823	833	848	860	873	891	908	924	941	953	

NOTES: 1. FOR CONSTANT TORQUE MOTORS: USE MOTOR TAPS 3-5 TO ACHIEVE RATED AIRFLOW AT AHRI MINIMUM EXTERNAL STATIC PRESSURE.

(a) Use * marked tap for AHRI 210/240-2023

(b) Use ** marked tap for AHRI 210/240-2017

2. GRAYED OUT PORTIONS NOT RECOMMENDED FOR USE IN FIELD.

DOWN DISCHARGE PRESSURE DROP (ADD TO EXTERNAL STATIC PRESSURE)							
CFM [L/s]	800 [378]	1000 [472]	1200 [566]	1400 [661]	1600 [755]	1800 [849]	2000 [944]
Pressure Drop—Includes W.C. [kPa]	.02 [.005]	.05 [.012]	.07 [.017]	.1 [.025]	.12 [.030]	.15 [.037]	.17 [.042]

[] Designates Metric Conversions

INDOOR AIRFLOW PERFORMANCE RGEAZR (208/230V, 3-PHASE) CONSTANT TORQUE MOTOR

Nominal Cooling Capacity Tons [kW]	Motor Speed from Factory		Recommended Speed Tap for Field Installed Heater Kit	Manufacturer Recommended Cooling Airflow (Min/Max)	Blower Size, Motor HP [W] & # of Speeds	Motor Tap - Usage	External Static Pressure - Inches W.C. [kPa] (Side Discharge-Dry Coil)										
	Cool	Heat					0.1 [.02]	0.2 [.05]	0.3 [.07]	0.4 [.10]	0.5 [.12]	0.6 [.15]	0.7 [.17]	0.8 [.20]	0.9 [.22]	1.0 [.25]	
3.0 [10.55]	Tap 3			1050 CFM / 1350 CFM	12x9T Blower 1 HP [746] 5 Speed (Constant Torque)	Tap 1 - FAN	CFM	977	915	833	764	700	557	475	398	338	295
							RPM	609	649	709	766	806	846	880	901	911	934
							Watts	115	118	130	141	147	154	159	164	165	167
							CFM	1058	1020	963	885	831	765	682	586	526	445
							RPM	646	680	725	795	832	875	912	953	970	988
							Watts	140	145	156	170	176	185	191	201	204	207
							CFM	1347	1314	1279	1245	1198	1128	1083	1038	985	923
							RPM	773	809	837	870	907	955	989	1037	1069	1107
							Watts	255	270	276	287	297	313	320	335	344	356
							CFM	1442	1417	1386	1349	1312	1252	1195	1143	1086	1044
							RPM	828	857	885	918	946	988	1028	1063	1094	1123
							Watts	313	323	332	343	353	367	380	390	402	412
							CFM	1336	1297	1264	1225	1188	1105	1043	984	931	867
							RPM	771	804	837	866	897	952	988	1022	1056	1083
							Watts	249	259	271	278	285	300	315	319	328	337
CFM	1486	1449	1418	1386	1351	1311	1240	1189	1135	1098							
RPM	840	874	902	930	958	988	1036	1069	1100	1130							
Watts	332	344	353	364	374	384	398	412	422	433							
CFM	1517	1493	1465	1429	1401	1364	1294	1249	1203	1148							
RPM	868	893	922	947	973	1003	1052	1088	1113	1145							
Watts	362	371	380	391	400	411	430	443	453	462							

[] Designates Metric Conversions

INDOOR AIRFLOW PERFORMANCE RGEAZR (208/230V, 3-PHASE) CONSTANT TORQUE MOTOR (Con't.)

Nominal Cooling Capacity Tons [kW]	Motor Speed from Factory		Recommended Speed Tap for Field Installed Heater Kit	Manufacturer Recommended Cooling Airflow (Min/Max)	Blower Size, Motor HP [W] & # of Speeds	Motor Tap - Usage	External Static Pressure - Inches W.C. [kPa]									
	Cool	Heat					0.1 [.02]	0.2 [.05]	0.3 [.07]	0.4 [.10]	0.5 [.12]	0.6 [.15]	0.7 [.17]	0.8 [.20]	0.9 [.22]	1.0 [.25]
							CFM	903	804	723	629	525	455	375	333	296
3.5 [12.31]		Tap 2	80,000 [23.45]	1225 CFM / 1575 CFM	12x9T Blower 3/4 HP [559] 5 Speed (Constant Torque)	Tap 1 - FAN	589	622	680	725	761	814	837	855	883	915
						Watts	106	110	119	127	132	141	145	146	152	157
						CFM	1440	1390	1354	1309	1257	1194	1136	1040	987	923
		Tap 2					801	828	861	896	937	973	1021	1047	1073	
							266	276	283	292	304	317	327	342	350	360
							1465	1414	1370	1334	1290	1228	1164	1100	1032	978
		Tap 2					775	810	841	869	899	938	974	1011	1048	1074
							277	287	297	305	314	327	337	349	362	371
		Tap 3					1557	1517	1475	1436	1398	1352	1306	1245	1178	1119
							821	849	882	908	936	966	997	1033	1068	1102
						330	339	350	360	370	381	390	403	415	428	
						1703	1659	1624	1589	1549	1508	1469	1424	1351	1263	
						870	900	926	952	979	1009	1033	1062	1102	1121	
						407	418	430	439	451	462	472	483	497	484	
						1832	1807	1775	1740	1704	1672	1639	1583	1505	1348	
						940	961	984	1009	1033	1061	1083	1103	1119	1136	
						519	530	540	552	562	577	586	583	570	531	

NOTES: 1. FOR CONSTANT TORQUE MOTORS: USE MOTOR TAPS 3-5 TO ACHIEVE RATED AIRFLOW AT AHRI MINIMUM EXTERNAL STATIC PRESSURE.

(a) Use * marked tap for AHRI 210/240-2023

(b) Use ** marked tap for AHRI 210/240-2017

2. GRAYED OUT PORTIONS NOT RECOMMENDED FOR USE IN FIELD.

DOWN DISCHARGE PRESSURE DROP (ADD TO EXTERNAL STATIC PRESSURE)					
CFM [L/s]	800 [378]	1000 [472]	1200 [566]	1600 [755]	2000 [944]
Pressure Drop—Includes W.C. [kPa]	.02 [.005]	.05 [.012]	.07 [.017]	.12 [.030]	.17 [.042]

[] Designates Metric Conversions

INDOOR AIRFLOW PERFORMANCE RGEAZR (208/230V, 3-PHASE) CONSTANT TORQUE MOTOR (Con't.)

Nominal Cooling Capacity Tons [kW]	Motor Speed from Factory		Recommended Speed Tap for Field Installed Heater Kit	Manufacturer Recommended Cooling Airflow (Min/Max)	Blower Size, Motor HP [W] & # of Speeds	Motor Tap - Usage	External Static Pressure - Inches W.C. [kPa] (Side Discharge-Dry Coil)										
	Cool	Heat					0.1 [.02]	0.2 [.05]	0.3 [.07]	0.4 [.10]	0.5 [.12]	0.6 [.15]	0.7 [.17]	0.8 [.20]	0.9 [.22]	1.0 [.25]	
4.0 [14.07]	Tap 3 - Low Stage	Tap 2	100,000 [29.31]	1400 CFM / 1800 CFM	12x9T Blower 1 HP [746] 5 Speed (Constant Torque)	Tap 1 - FAN	CFM	1015	893	805	710	580	500	428	339	310	288
							RPM	591	618	671	721	760	805	829	851	873	913
							Watts	110	105	114	120	127	133	136	140	144	150
							CFM	1398	1357	1314	1269	1218	1159	1092	1014	952	883
							RPM	751	783	815	844	876	914	953	994	1025	1059
	Tap 4 - High Stage	Tap 2	100,000 [29.31]	1400 CFM / 1800 CFM	12x9T Blower 1 HP [746] 5 Speed (Constant Torque)	Tap 2 - 100K	CFM	1467	1429	1382	1337	1301	1246	1171	1120	1047	990
							RPM	786	812	847	878	902	936	979	1012	1049	1078
							Watts	272	280	291	298	305	316	330	340	351	362
							CFM	1306	1257	1203	1159	1103	1027	953	879	813	751
							RPM	716	750	786	817	854	897	937	971	998	1033
Tap 4 - High Stage	Tap 2	100,000 [29.31]	1400 CFM / 1800 CFM	12x9T Blower 1 HP [746] 5 Speed (Constant Torque)	Tap 3 - Low Stage Cool	Watts	201	209	218	225	235	245	253	263	265	278	
						CFM	1790	1755	1719	1686	1653	1611	1580	1539	1493	1358	
						RPM	918	944	969	996	1020	1050	1069	1097	1124	1144	
						Watts	455	466	478	489	499	512	520	530	543	511	
						CFM	1869	1835	1800	1768	1729	1692	1653	1605	1536	1358	
Tap 4 - High Stage	Tap 2	100,000 [29.31]	1400 CFM / 1800 CFM	12x9T Blower 1 HP [746] 5 Speed (Constant Torque)	Tap 5 - High Stage Cool**	RPM	942	970	992	1018	1044	1076	1101	1120	1130	1144	
						Watts	506	518	529	541	550	568	578	579	563	518	
						CFM	1869	1835	1800	1768	1729	1692	1653	1605	1536	1358	
						RPM	942	970	992	1018	1044	1076	1101	1120	1130	1144	
						Watts	506	518	529	541	550	568	578	579	563	518	

[J] Designates Metric Conversions

INDOOR AIRFLOW PERFORMANCE RGEAZR (208/230V, 1-PHASE) CONSTANT TORQUE MOTOR (Con't.)

Nominal Cooling Capacity Tons [kW]	Motor Speed from Factory		Recommended Speed Tap for Field Installed Heater Kit	Manufacturer Recommended Cooling Airflow (Min/Max)	Blower Size, Motor HP [W] & # of Speeds	Motor Tap - Usage	External Static Pressure - Inches W.C. [kPa]											
	Cool	Heat					0.1 [.02]	0.2 [.05]	0.3 [.07]	0.4 [.10]	0.5 [.12]	0.6 [.15]	0.7 [.17]	0.8 [.20]	0.9 [.22]	1.0 [.25]		
5.0 [17.59]		Tap 2	80,000 [23.45]	1750 CFM / 2250 CFM	12x9R Blower 1 HP [746] 5 Speed (Constant Torque)	Tap 1 - FAN	CFM 999	856	786	694	575	502	428	379	331	280		
						Watts 590	599	640	681	715	752	789	814	847	871			
	Tap 2 - 80K	CFM 1373	1328	1291		1244	1197	1144	1088	1032	978	931						
		Watts 742	773	804		833	862	895	926	953	977	1001						
	Tap 3 - Low Stage	CFM 1438	1392	1356		1318	1273	1223	1172	1115	1056	1009						
		Watts 772	801	832		856	883	915	945	975	1000	1026						
	Tap 4 - High Stage	CFM 1355	1316	1276		1227	1165	1111	1041	990	928	873						
		Watts 735	764	793		826	854	885	914	936	962	992						
								Tap 2 - Low Stage Cool	Watts 237	245	253	262	268	277	284	289	296	302
								CFM 1845	1812	1779	1749	1711	1691	1654	1624	1581	1546	
						Tap 4 - High Stage Cool**	RPM 941	963	983	1009	1035	1054	1077	1098	1127	1152		
						Watts 537	549	559	570	584	593	604	617	632	646			
						Tap 5 - High Stage Cool	CFM 2138	2106	2084	2050	1990	1963	1943	1914	1891			
						Watts 1057	1075	1094	1117	1134	1162	1186	1206	1229	1245			
						High Static	Watts 823	833	848	860	873	891	908	924	941	953		

NOTES: 1. FOR CONSTANT TORQUE MOTORS: USE MOTOR TAPS 3-5 TO ACHIEVE RATED AIRFLOW AT AHRI MINIMUM EXTERNAL STATIC PRESSURE.

(a) Use * marked tap for AHRI 210/240-2023

(b) Use ** marked tap for AHRI 210/240-2017

2. GRAYED OUT PORTIONS NOT RECOMMENDED FOR USE IN FIELD.

DOWN DISCHARGE PRESSURE DROP (ADD TO EXTERNAL STATIC PRESSURE)			
CFM [L/s]	800 [378]	1000 [472]	1200 [566]
Pressure Drop—Includes W.C. [kPa]	.02 [.005]	.05 [.012]	.07 [.017]
			1400 [661]
			1600 [755]
			1800 [849]
			2000 [944]
			.12 [.030]
			.15 [.037]
			.17 [.042]

[] Designates Metric Conversions

INDOOR AIRFLOW PERFORMANCE RGEAZR (460V, 3-PHASE) CONSTANT TORQUE MOTOR (Con't.)

Nominal Cooling Capacity Tons [kW]	Motor Speed from Factory		Recommended Speed Tap for Field Installed Heater Kit	Manufacturer Recommended Cooling Airflow (Min/Max)	Blower Size, Motor HP [W] & # of Speeds	Motor Tap - Usage	External Static Pressure - Inches W.C. [kPa]									
	Cool	Heat					0.1 [.02]	0.2 [.05]	0.3 [.07]	0.4 [.10]	0.5 [.12]	0.6 [.15]	0.7 [.17]	0.8 [.20]	0.9 [.22]	1.0 [.25]
							CFM	831	758	674	531	468	409	354	295	238
5.0 [17.59]	Tap 3 - Low Stage	Tap 2	80,000 [23.45]	1750 CFM / 2250 CFM	12x9R Blower 1 HP [746] 5 Speed (Constant Torque)	Tap 1 - FAN	582	595	635	678	720	753	780	810	842	873
						Watts	117	104	110	116	123	128	133	137	142	146
5.0 [17.59]	Tap 4 - High Stage	Tap 2	80,000 [23.45]	1750 CFM / 2250 CFM	12x9R Blower 1 HP [746] 5 Speed (Constant Torque)	Tap 2 - 80K	1361	1319	1287	1242	1190	1131	1081	1023	973	921
						RPM	743	771	799	833	865	900	928	953	982	1015
5.0 [17.59]	Tap 3 - Low Stage	Tap 2	100,000 [29.31]	1750 CFM / 2250 CFM	12x9R Blower 1 HP [746] 5 Speed (Constant Torque)	Tap 2 - 100K	1407	1365	1335	1294	1247	1189	1131	1081	1034	981
						RPM	761	790	817	845	879	912	946	970	994	1031
5.0 [17.59]	Tap 4 - High Stage	Tap 2	100,000 [29.31]	1750 CFM / 2250 CFM	12x9R Blower 1 HP [746] 5 Speed (Constant Torque)	Tap 3 - Low Stage	1346	1306	1270	1228	1179	1120	1051	1004	953	898
						RPM	729	759	791	820	856	893	926	949	976	1013
5.0 [17.59]	Tap 4 - High Stage	Tap 2	100,000 [29.31]	1750 CFM / 2250 CFM	12x9R Blower 1 HP [746] 5 Speed (Constant Torque)	Tap 3 - Low Stage	247	256	266	276	287	299	309	316	324	336
						Watts	1840	1807	1781	1751	1722	1690	1666	1630	1593	1552
5.0 [17.59]	Tap 4 - High Stage	Tap 2	100,000 [29.31]	1750 CFM / 2250 CFM	12x9R Blower 1 HP [746] 5 Speed (Constant Torque)	Tap 4 - High Stage	932	955	979	1004	1027	1049	1073	1097	1122	1150
						RPM	561	575	588	600	614	626	637	651	666	683
5.0 [17.59]	Tap 4 - High Stage	Tap 2	100,000 [29.31]	1750 CFM / 2250 CFM	12x9R Blower 1 HP [746] 5 Speed (Constant Torque)	Tap 5 - High Stage	2137	2104	2078	2051	2014	1983	1954	1926	1894	1855
						RPM	1067	1083	1097	1122	1138	1164	1182	1198	1215	1237
5.0 [17.59]	Tap 4 - High Stage	Tap 2	100,000 [29.31]	1750 CFM / 2250 CFM	12x9R Blower 1 HP [746] 5 Speed (Constant Torque)	High Static	876	889	898	912	924	936	947	957	968	978
						Watts										

NOTES: 1. FOR CONSTANT TORQUE MOTORS: USE MOTOR TAPS 3-5 TO ACHIEVE RATED AIRFLOW AT AHRI MINIMUM EXTERNAL STATIC PRESSURE.

(a) Use * marked tap for AHRI 210/240-2023

(b) Use ** marked tap for AHRI 210/240-2017

2. GRAYED OUT PORTIONS NOT RECOMMENDED FOR USE IN FIELD.

DOWN DISCHARGE PRESSURE DROP (ADD TO EXTERNAL STATIC PRESSURE)							
CFM [L/s]	800 [378]	1000 [472]	1200 [566]	1400 [661]	1600 [755]	1800 [849]	2000 [944]
Pressure Drop—Includes W.C. [kPa]	.02 [.005]	.05 [.012]	.07 [.017]	.1 [.025]	.12 [.030]	.15 [.037]	.17 [.042]

[] Designates Metric Conversions

INDOOR AIRFLOW PERFORMANCE RGEAZR ULN (208/230V, 1-PHASE) CONSTANT TORQUE MOTOR

Nominal Cooling Capacity Tons [kW]	Motor Speed from Factory		Heating Input BTU/HR [kW]	Manufacturer Recommended Cooling Airflow (Min/Max)	Blower Size, Motor HP [W] & # of Speeds	Motor Tap - Usage	External Static Pressure - Inches W.C. [kPa] (Side Discharge-Dry Coil)										
	Cool	Heat					0.1 [.02]	0.2 [.05]	0.3 [.07]	0.4 [.10]	0.5 [.12]	0.6 [.15]	0.7 [.17]	0.8 [.20]	0.9 [.22]	1.0 [.25]	
2.0 [7.03]	Tap 3			700 CFM / 900 CFM	10X9 Blower 1/3 HP [249] 5 Speed (Constant Torque)	Tap 1 - FAN	CFM	890	842	788	736	660	623	579	521	462	408
							RPM	680	729	763	835	895	926	967	1021	1062	1098
							Watts	111	118	124	132	140	144	150	157	162	167
							CFM	744	686	553	502	454	399	324	276	240	212
							RPM	601	658	737	778	822	882	921	957	1000	1046
							Watts	74	80	88	92	97	103	106	110	115	119
							CFM	880	839	784	713	650	578	530	469	423	375
							RPM	674	718	775	841	888	920	960	1015	1052	1089
							Watts	108	114	121	130	137	141	147	153	158	163
							CFM	874	825	771	703	590	553	511	451	398	347
RPM	671	721	774	842	888	921	959	1016	1057	1092							
Watts	105	112	119	128	134	138	143	150	156	160							
CFM	1037	1000	957	905	838	776	738	701	668	616							
RPM	757	796	839	886	949	994	1026	1057	1089	1128							
Watts	156	163	171	178	190	197	204	207	214	217							
CFM	1274	1239	1208	1168	1138	1098	1024	865	796	713							
RPM	882	922	953	989	1027	1066	1101	1131	1138	1149							
Watts	268	277	285	295	303	313	312	285	272	253							
CFM	944	895	852	801	716	669	633	585	546	498							
RPM	715	760	805	855	923	964	993	1031	1085	1118							
Watts	128	135	141	149	159	165	170	176	184	190							
CFM	713	564	483	438	375	296	248	220	189								
RPM	591	635	708	749	817	862	902	955	989								
Watts	68	69	75	78	84	89	92	97	101								
CFM	870	826	766	689	646	599	558	490	430	402							
RPM	675	719	776	848	882	921	958	1013	1057	1083							
Watts	106	111	119	129	132	139	143	151	157	160							
CFM	980	930	891	840	764	717	676	646	602	536							
RPM	731	775	814	866	935	970	1002	1030	1076	1131							
Watts	138	144	149	159	171	175	181	185	193	202							
CFM	1212	1178	1144	1103	1064	1018	966	912	829	734							
RPM	856	897	935	967	1011	1054	1102	1136	1151	1160							
Watts	235	244	253	260	271	280	291	293	279	261							
CFM	1549	1522	1463	1404	1339	1270	1161	970	857	769							
RPM	1044	1074	1099	1113	1124	1134	1147	1162	1167	1174							
Watts	464	472	467	462	432	411	378	325	298	281							

[] Designates Metric Conversions

**INDOOR AIRFLOW PERFORMANCE RGEAZR ULN (208/230V, 1-PHASE)
CONSTANT TORQUE MOTOR (Con't.)**

Nominal Cooling Capacity Tons [kW]	Motor Speed from Factory		Heating Input BTU/HR [kW]	Manufacturer Recommended Cooling Airflow (Min/Max)	Blower Size, Motor HP [W] & # of Speeds	Motor Tap - Usage	External Static Pressure - Inches W.C. [kPa] (Side Discharge-Dry Coil)										
	Cool	Heat					0.1 [.02]	0.2 [.05]	0.3 [.07]	0.4 [.10]	0.5 [.12]	0.6 [.15]	0.7 [.17]	0.8 [.20]	0.9 [.22]	1.0 [.25]	
3.0 [10.55]	Tap 5		60,000 [17.58]	1050 CFM / 1350 CFM	12x9T Blower 1 HP [746] 5 Speed (Constant Torque)	Tap 1 - FAN	CFM	967	917	840	779	708	580	492	419	335	300
							RPM	615	658	718	771	817	855	887	911	929	943
							Watts	118	126	136	145	152	160	164	168	171	176
						Tap 2 - 60K	CFM	922	854	766	698	553	466	400	325	286	256
							RPM	592	629	700	748	796	834	856	875	885	928
							Watts	107	110	119	127	133	140	143	147	149	153
						Tap 2 - 80K	CFM	1152	1116	1071	993	939	883	824	762	684	612
							RPM	700	733	773	831	870	917	955	989	1025	1048
							Watts	179	188	197	206	219	229	237	246	255	262
						Tap 3 - Low Static Cool	CFM	1336	1297	1264	1225	1188	1105	1043	984	931	867
	RPM	771	804	837	866	897	952	988	1022	1056	1083						
	Watts	249	259	271	278	285	300	315	319	328	337						
Tap 4 - Med Static Cool*	CFM	1486	1449	1418	1386	1351	1311	1240	1189	1135	1098						
	RPM	840	874	902	930	958	988	1036	1069	1100	1130						
	Watts	332	344	353	364	374	384	398	412	422	433						
Tap 5 - High Static Cool	CFM	1517	1493	1465	1429	1401	1364	1294	1249	1203	1148						
	RPM	868	893	922	947	973	1003	1052	1088	1113	1145						
	Watts	362	371	380	391	400	411	430	443	453	462						

NOTES: 1. FOR CONSTANT TORQUE MOTORS: USE MOTOR TAPS 3-5 TO ACHIEVE RATED AIRFLOW AT AHRI MINIMUM EXTERNAL STATIC PRESSURE.

(a) Use * marked tap for AHRI 210/240-2023

(b) Use ** marked tap for AHRI 210/240-2017

2. GRAYED OUT PORTIONS NOT RECOMMENDED FOR USE IN FIELD.

DOWN DISCHARGE PRESSURE DROP (ADD TO EXTERNAL STATIC PRESSURE)			
CFM [L/s]	800 [378]	1000 [472]	2000 [944]
Pressure Drop—Includes W.C. [kPa]	.02 [.005]	.05 [.012]	.17 [.042]

[] Designates Metric Conversions

INDOOR AIRFLOW PERFORMANCE RGEAZR ULN (208/230V, 1-PHASE) CONSTANT TORQUE MOTOR

Nominal Cooling Capacity Tons [kW]	Motor Speed from Factory		Heating Input BTU/HR [kW]	Manufacturer Recommended Cooling Airflow (Min/Max)	Blower Size, Motor HP [W] & # of Speeds	Motor Tap - Usage	External Static Pressure - Inches W.C. [kPa] (Side Discharge-Dry Coil)										
	Cool	Heat					0.1 [.02]	0.2 [.05]	0.3 [.07]	0.4 [.10]	0.5 [.12]	0.6 [.15]	0.7 [.17]	0.8 [.20]	0.9 [.22]	1.0 [.25]	
3.5 [12.31]	Tap 5		80,000 [23.45]	1225 CFM / 1575 CFM	12x9T Blower 3/4 HP [559] 5 Speed (Constant Torque)	Tap 1 - FAN	CFM	1130	1077	1027	946	841	764	692	634	551	497
							RPM	647	685	723	770	822	854	905	929	956	974
							Watts	148	155	164	174	182	190	198	206	210	215
							CFM	1317	1266	1226	1170	1105	1032	945	873	817	748
							RPM	718	753	785	821	863	904	947	977	1001	1051
							Watts	213	221	231	239	250	261	271	280	286	298
							CFM	1557	1517	1475	1436	1398	1352	1306	1245	1178	1119
							RPM	821	849	882	908	936	966	997	1033	1068	1102
							Watts	330	339	350	360	370	381	390	403	415	428
							CFM	1703	1659	1624	1589	1549	1508	1469	1424	1351	1263
RPM	870	900	926	952	979	1009	1033	1062	1102	1121							
Watts	407	418	430	439	451	462	472	483	497	484							
CFM	1832	1807	1775	1740	1704	1672	1639	1583	1505	1348							
RPM	940	961	984	1009	1033	1061	1083	1103	1119	1136							
Watts	519	530	540	552	562	577	586	583	570	531							
4.0 [14.07]	Tap 5		80,000 [23.45]	1400 CFM 1800 CFM*	12x9R Blower 1 HP [746] 5 Speed (Constant Torque)	Tap 1 - FAN	CFM	1174	1130	1076	1026	947	872	810	744	689	641
							RPM	664	696	729	759	800	828	860	897	924	942
							Watts	166	173	180	187	195	201	208	217	223	227
							CFM	1262	1220	1175	1117	1058	993	923	870	805	751
							RPM	695	726	756	788	824	856	884	908	948	974
							Watts	197	203	211	218	227	235	242	248	258	265
							CFM	1460	1416	1385	1342	1298	1253	1200	1128	1076	1037
							RPM	780	811	837	865	893	919	949	981	1003	1024
							Watts	285	296	303	313	322	329	340	349	358	364
							CFM	1354	1316	1273	1229	1179	1121	1062	997	954	891
RPM	745	773	802	826	856	888	919	945	968	1007							
Watts	239	247	255	260	270	280	287	295	301	312							
CFM	1769	1734	1706	1665	1634	1595	1560	1526	1481	1444							
RPM	903	931	953	980	999	1028	1048	1071	1094	1117							
Watts	468	481	490	500	511	524	532	543	554	566							
CFM	1966	1938	1916	1882	1855	1822	1803	1778	1739	1700							
RPM	1003	1027	1047	1070	1091	1115	1128	1150	1172	1195							
Watts	657	670	682	695	707	721	730	742	756	769							

[*] Designates Metric Conversions

**INDOOR AIRFLOW PERFORMANCE RGEAZR ULN (208/230V, 1-PHASE)
CONSTANT TORQUE MOTOR (Con't.)**

Nominal Cooling Capacity Tons [kW]	Motor Speed from Factory		Heating Input BTU/HR [kW]	Manufacturer Recommended Cooling Airflow (Min/Max)	Blower Size, Motor HP [W] & # of Speeds	Motor Tap - Usage	External Static Pressure - Inches W.C. [kPa] (Side Discharge-Dry Coil)										
	Cool	Heat					0.1 [.02]	0.2 [.05]	0.3 [.07]	0.4 [.10]	0.5 [.12]	0.6 [.15]	0.7 [.17]	0.8 [.20]	0.9 [.22]	1.0 [.25]	
5.0 [17.59]	Tap 5		100,000 [29.31]	1750 CFM / 2250 CFM	12x9R Blower 1 HP [746] 5 Speed (Constant Torque)	Tap 1 - FAN	CFM	1171	1124	1068	1012	943	886	829	766	702	642
							RPM	659	692	727	762	800	829	857	891	924	953
							Watts	166	173	181	190	197	204	209	218	225	233
						Tap 2 - 100K	CFM	1567	1532	1495	1460	1418	1383	1340	1291	1244	1186
							RPM	828	854	879	907	935	960	985	1012	1042	1070
							Watts	350	361	371	380	391	400	410	420	430	442
						Tap 3 - Low Stage Cool	CFM	1419	1381	1350	1301	1256	1207	1140	1086	1035	977
							RPM	763	791	817	847	876	909	943	970	995	1020
							Watts	268	277	285	295	304	314	323	332	340	348
						Tap 4 - High Stage Cool* Med Static	CFM	1938	1904	1873	1841	1813	1811	1754	1726	1694	1661
	RPM	976	1002	1019	1043	1063	1065	1107	1130	1159	1180						
	Watts	622	638	645	657	669	670	693	707	725	737						
Tap 5 - High Stage Cool	CFM	2138	2106	2084	2050	2025	1990	1963	1943	1914	1891						
	RPM	1057	1075	1094	1117	1134	1162	1186	1206	1229	1245						
	Watts	823	833	848	860	873	891	908	924	941	953						

NOTES: 1. FOR CONSTANT TORQUE MOTORS: USE MOTOR TAPS 3-5 TO ACHIEVE RATED AIRFLOW AT AHRI MINIMUM EXTERNAL STATIC PRESSURE.

(a) Use * marked tap for AHRI 210/240-2023

(b) Use ** marked tap for AHRI 210/240-2017

2. GRAYED OUT PORTIONS NOT RECOMMENDED FOR USE IN FIELD.

DOWN DISCHARGE PRESSURE DROP (ADD TO EXTERNAL STATIC PRESSURE)			
CFM [L/s]	800 [378]	1000 [472]	2000 [944]
Pressure Drop—Includes W.C. [kPa]	.02 [.005]	.05 [.012]	.12 [.030]
			.17 [.042]

[] Designates Metric Conversions

INDOOR AIRFLOW PERFORMANCE RGEAZR ULN (208/230V, 3-PHASE) CONSTANT TORQUE MOTOR

Nominal Cooling Capacity Tons [kW]	Motor Speed from Factory		Heating Input BTU/HR [kW]	Manufacturer Recommended Cooling Airflow (Min/Max)	Blower Size, Motor HP [W] & # of Speeds	Motor Tap - Usage	External Static Pressure - Inches W.C. [kPa] (Side Discharge-Dry Coil)															
	Cool	Heat					0.1 [.02]	0.2 [.05]	0.3 [.07]	0.4 [.10]	0.5 [.12]	0.6 [.15]	0.7 [.17]	0.8 [.20]	0.9 [.22]	1.0 [.25]						
3.0 [10.55]	Tap 5		60,000 [17.58]	1050 CFM / 1350 CFM	12x9T Blower 1 HP [746] 5 Speed (Constant Torque)	Tap 1 - FAN	CFM	967	917	840	779	708	580	492	419	335	300					
							RPM	615	658	718	771	817	855	887	911	929	943					
							Watts	118	126	136	145	152	160	164	168	171	176					
		Tap 2		60,000 [17.58]		1050 CFM / 1350 CFM	12x9T Blower 1 HP [746] 5 Speed (Constant Torque)	Tap 2 - 60K	CFM	922	854	766	698	553	466	400	325	286	256			
									RPM	592	629	700	748	796	834	856	875	885	928			
									Watts	107	110	119	127	133	140	143	147	149	153			
		Tap 2	80,000 [23.45]			1050 CFM / 1350 CFM		12x9T Blower 1 HP [746] 5 Speed (Constant Torque)	Tap 2 - 80K	CFM	1152	1116	1071	993	939	883	824	762	684	612		
										RPM	700	733	773	831	870	917	955	989	1025	1048		
										Watts	179	188	197	206	219	229	237	246	255	262		
		Tap 3				1050 CFM / 1350 CFM			12x9T Blower 1 HP [746] 5 Speed (Constant Torque)	Tap 3 - Low Static Cool **	CFM	1336	1297	1264	1225	1188	1105	1043	984	931	867	
											RPM	771	804	837	866	897	952	988	1022	1056	1083	
											Watts	249	259	271	278	285	300	315	319	328	337	
		Tap 4				1050 CFM / 1350 CFM				12x9T Blower 1 HP [746] 5 Speed (Constant Torque)	Tap 4 - Med Static Cool	CFM	1486	1449	1418	1386	1351	1311	1240	1189	1135	1098
												RPM	840	874	902	930	958	988	1036	1069	1100	1130
												Watts	332	344	353	364	374	384	398	412	422	433
Tap 5			1050 CFM / 1350 CFM	12x9T Blower 1 HP [746] 5 Speed (Constant Torque)	Tap 5 - High Static Cool	CFM					1517	1493	1465	1429	1401	1364	1294	1249	1203	1148		
						RPM					868	893	922	947	973	1003	1052	1088	1113	1145		
						Watts					362	371	380	391	400	411	430	443	453	462		

[] Designates Metric Conversions

INDOOR AIRFLOW PERFORMANCE RGEAZR ULN (208/230V, 3-PHASE) CONSTANT TORQUE MOTOR

Nominal Cooling Capacity Tons [kW]	Motor Speed from Factory		Heating Input BTU/HR [kW]	Manufacturer Recommended Cooling Airflow (Min/Max)	Blower Size, Motor HP [W] & # of Speeds	Motor Tap - Usage	External Static Pressure - Inches W.C. [kPa] (Side Discharge-Dry Coil)										
	Cool	Heat					0.1 [.02]	0.2 [.05]	0.3 [.07]	0.4 [.10]	0.5 [.12]	0.6 [.15]	0.7 [.17]	0.8 [.20]	0.9 [.22]	1.0 [.25]	
4.0 [14.07]	Tap 5			1400 CFM / 1800 CFM	12x9T Blower 1 HP [746] 5 Speed (Constant Torque)	Tap 1 - FAN	CFM	1206	1156	1102	1054	968	886	809	724	668	590
							RPM	672	707	746	776	828	868	906	951	975	1007
							Watts	164	172	181	187	199	206	214	224	230	237
						Tap 2 - 80K	CFM	1306	1257	1203	1159	1103	1027	953	879	813	751
							RPM	716	750	786	817	854	897	937	971	998	1033
							Watts	201	209	218	225	235	245	253	263	265	278
						Tap 2 - 100K	CFM	1466	1427	1382	1339	1292	1240	1161	1088	1048	983
							RPM	785	816	845	875	906	937	986	1022	1047	1079
							Watts	271	280	288	298	304	316	331	342	349	359
							CFM	1306	1257	1203	1159	1103	1027	953	879	813	751
	RPM	716	750	786	817	854	897	937	971	998	1033						
	Watts	201	209	218	225	235	245	253	263	265	278						
	CFM	1790	1755	1719	1686	1653	1611	1580	1539	1493	1358						
	RPM	918	944	969	996	1020	1050	1069	1097	1124	1144						
	Watts	455	466	478	489	499	512	520	530	543	511						
	CFM	1869	1835	1800	1768	1729	1692	1653	1605	1536	1358						
	RPM	942	970	992	1018	1044	1076	1101	1120	1130	1144						
	Watts	506	518	529	541	550	568	578	579	563	518						

[J] Designates Metric Conversions

**INDOOR AIRFLOW PERFORMANCE RGEAZR ULN (208/230V, 3-PHASE)
CONSTANT TORQUE MOTOR (Con't.)**

Nominal Cooling Capacity Tons [kW]	Motor Speed from Factory		Heating Input BTU/HR [kW]	Manufacturer Recommended Cooling Airflow (Min/Max)	Blower Size, Motor HP [W] & # of Speeds	Motor Tap - Usage	External Static Pressure - Inches W.C. [kPa] (Side Discharge-Dry Coil)										
	Cool	Heat					0.1 [.02]	0.2 [.05]	0.3 [.07]	0.4 [.10]	0.5 [.12]	0.6 [.15]	0.7 [.17]	0.8 [.20]	0.9 [.22]	1.0 [.25]	
5.0 [17.59]	Tap 5		100,000 [29.31]	1750 CFM / 2250 CFM	12x9R Blower 1 HP [746] 5 Speed (Constant Torque)	Tap 1 - FAN	CFM	1171	1124	1068	1012	943	886	829	766	702	642
							RPM	659	692	727	762	800	829	857	891	924	953
							Watts	166	173	181	190	197	204	209	218	225	233
						Tap 2 - 100K	CFM	1567	1532	1495	1460	1418	1383	1340	1291	1244	1186
							RPM	828	854	879	907	935	960	985	1012	1042	1070
							Watts	350	361	371	380	391	400	410	420	430	442
						Tap 3 - Low Stage Cool	CFM	1355	1316	1276	1227	1165	1111	1041	990	928	873
							RPM	735	764	793	826	854	885	914	936	962	992
							Watts	237	245	253	262	268	277	284	289	296	302
						Tap 4 - High Stage Cool**	CFM	1845	1812	1779	1749	1711	1691	1654	1624	1581	1546
	RPM	941	963	983	1009	1035	1054	1077	1098	1127	1152						
	Watts	537	549	559	570	584	593	604	617	632	646						
Tap 5 - High Stage Cool	CFM	2138	2106	2084	2050	2025	1990	1963	1943	1914	1891						
	RPM	1057	1075	1094	1117	1134	1162	1186	1206	1229	1245						
	Watts	823	833	848	860	873	891	908	924	941	953						

NOTES: 1. FOR CONSTANT TORQUE MOTORS: USE MOTOR TAPS 3-5 TO ACHIEVE RATED AIRFLOW AT AHRI MINIMUM EXTERNAL STATIC PRESSURE.

(a) Use * marked tap for AHRI 210/240-2023

(b) Use ** marked tap for AHRI 210/240-2017

2. GRAYED OUT PORTIONS NOT RECOMMENDED FOR USE IN FIELD.

DOWN DISCHARGE PRESSURE DROP (ADD TO EXTERNAL STATIC PRESSURE)			
CFM [L/s]	800 [378]	1000 [472]	2000 [944]
Pressure Drop—Includes W.C. [kPa]	.02 [.005]	.05 [.012]	.12 [.030]
			.15 [.037]
			.17 [.042]

[] Designates Metric Conversions

INDOOR AIRFLOW PERFORMANCE RGEAZR ULN (460V, 3-PHASE) CONSTANT TORQUE MOTOR

Nominal Cooling Capacity Tons [kW]	Motor Speed from Factory		Heating Input BTU/HR [kW]	Manufacturer Recommended Cooling Airflow (Min/Max)	Blower Size, Motor HP [W] & # of Speeds	Motor Tap - Usage	External Static Pressure - Inches W.C. [kPa] (Side Discharge-Dry Coil)									
	Cool	Heat					0.1 [.02]	0.2 [.05]	0.3 [.07]	0.4 [.10]	0.5 [.12]	0.6 [.15]	0.7 [.17]	0.8 [.20]	0.9 [.22]	1.0 [.25]
3.0 [10.55]	Tap 5			1050 CFM / 1350 CFM	12x9T Blower 1 HP [746] 5 Speed (Constant Torque)	Tap 1 - FAN	CFM	964	839	775	707	643	537	473	388	335
							RPM	603	708	758	804	842	887	908	931	940
							Watts	121	140	150	160	167	176	180	184	187
							CFM	942	882	733	661	532	453	376	320	300
							RPM	592	693	746	791	840	869	889	904	938
							Watts	113	130	140	148	157	163	167	168	176
							CFM	1099	1066	954	896	873	814	741	653	586
							RPM	667	740	798	843	894	930	961	1001	1025
							Watts	167	184	199	209	222	230	239	248	254
							CFM	1292	1278	1254	1168	1108	1050	999	950	902
RPM	770	794	827	857	903	947	986	1019	1050							
Watts	259	266	278	287	303	317	330	340	350							
CFM	1425	1417	1398	1373	1343	1307	1248	1188	1135							
RPM	841	860	884	914	940	970	1018	1060	1093							
Watts	342	349	359	370	380	392	410	426	440							
CFM	1470	1464	1444	1419	1390	1361	1323	1252	1196							
RPM	865	880	905	932	958	985	1016	1068	1108							
Watts	370	376	388	399	409	420	433	455	470							
CFM	1193	1141	1091	1038	959	879	805	735	666							
RPM	667	708	742	781	828	871	905	938	980							
Watts	168	177	186	195	207	218	225	234	245							
CFM	1314	1272	1227	1186	1129	1058	983	913	846							
RPM	720	754	790	821	858	904	943	973	1005							
Watts	214	224	234	244	254	267	278	287	296							
CFM	1492	1453	1409	1376	1336	1290	1232	1162	1100							
RPM	792	822	858	885	913	945	984	1024	1057							
Watts	295	307	318	328	338	349	363	377	389							
CFM	1295	1254	1212	1163	1107	1030	948	883	812							
RPM	710	741	778	810	849	893	935	967	995							
Watts	207	216	225	234	246	257	268	277	285							
CFM	1822	1788	1752	1724	1695	1659	1625	1594	1541							
RPM	921	946	972	997	1020	1050	1074	1097	1125							
Watts	491	505	519	530	541	554	565	579	590							
CFM																
RPM																
Watts																
CFM																
RPM																
Watts																

[] Designates Metric Conversions

Nominal Cooling Capacity Tons [kW]	Motor Speed from Factory		Heating Input BTU/HR [kW]	Manufacturer Recommended Cooling Airflow (Min/Max)	Blower Size, Motor HP [W] & # of Speeds	Motor Tap - Usage	External Static Pressure - Inches W.C. [kPa]											
	Cool	Heat					(Side Discharge-Dry Coil)											
							0.1 [.02]	0.2 [.05]	0.3 [.07]	0.4 [.10]	0.5 [.12]	0.6 [.15]	0.7 [.17]	0.8 [.20]	0.9 [.22]	1.0 [.25]		
5.0 [17.59]		Tap 5		1750 CFM / 2250 CFM	12x9R Blower 1 HP [746] 5 Speed (Constant Torque)	Tap 1 - FAN	CFM	1177	1130	1075	1024	949	886	832	773	700	663	
							RPM	662	692	729	762	802	829	862	893	928	946	
							Watts	175	182	191	200	210	217	225	233	241	247	
				Tap 2 - 100K				CFM	1558	1519	1485	1454	1413	1369	1328	1280	1229	1173
								RPM	825	849	879	905	932	962	989	1019	1047	1073
								Watts	362	374	385	395	408	420	433	445	456	467
								CFM	1346	1306	1270	1228	1179	1120	1051	1004	953	898
								RPM	729	759	791	820	856	893	926	949	976	1013
								Watts	247	256	266	276	287	299	309	316	324	336
								CFM	1840	1807	1781	1751	1722	1690	1666	1630	1593	1552
						RPM	932	955	979	1004	1027	1049	1073	1097	1122	1150		
						Watts	561	575	588	600	614	626	637	651	666	683		
						CFM	2137	2104	2078	2051	2014	1983	1954	1926	1894	1855		
						RPM	1067	1083	1097	1122	1138	1164	1182	1198	1215	1237		
						Watts	876	889	898	912	924	936	947	957	968	978		

NOTES: 1. FOR CONSTANT TORQUE MOTORS: USE MOTOR TAPS 3-5 TO ACHIEVE RATED AIRFLOW AT AHRI MINIMUM EXTERNAL STATIC PRESSURE.

(a) Use * marked tap for AHRI 210/240-2023

(b) Use ** marked tap for AHRI 210/240-2017

2. GRAYED OUT PORTIONS NOT RECOMMENDED FOR USE IN FIELD.

DOWN DISCHARGE PRESSURE DROP (ADD TO EXTERNAL STATIC PRESSURE)			
CFM [L/s]	800 [378]	1000 [472]	2000 [944]
Pressure Drop—Includes W.C. [kPa]	.02 [.005]	.05 [.012]	.12 [.030]
	.07 [.017]	.15 [.037]	.17 [.042]

[] Designates Metric Conversions

ELECTRICAL DATA - RGEAZR SERIES

		024AJT041/X	024AJT04U	024AJT061/X	024AJT06U	024AJT081/X	030AJT041/X	030AJT04U	030AJT061/X
Unit Information	Unit Operating Voltage Range	187-253	187-253	187-253	187-253	187-253	187-253	187-253	187-253
	Volts	208/230	208/230	208/230	208/230	208/230	208/230	208/230	208/230
	Phase	1	1	1	1	1	1	1	1
	Hz	60	60	60	60	60	60	60	60
	Minimum Circuit Ampacity	18	18	18	18	18	21	21	21
	Minimum Overcurrent Protection Device Size	25	25	25	25	25	25	25	25
	Maximum Overcurrent Protection Device Size	25	25	25	25	25	30	30	30
Compressor Motor	No.	1	1	1	1	1	1	1	1
	Volts	208/230	208/230	208/230	208/230	208/230	208/230	208/230	208/230
	Phase	1	1	1	1	1	1	1	1
	RPM	3500	3500	3500	3500	3500	3500	3500	3500
	HP, Compressor 1								
	Amps (RLA), Comp. 1	10.8	10.8	10.8	10.8	10.8	12.3	12.3	12.3
	Amps (LRA), Comp. 1	55	55	55	55	55	63	63	63
	HP, Compressor 2								
	Amps (RLA), Comp. 2								
	Amps (LRA), Comp. 2								
Condenser Motor	No.	1	1	1	1	1	1	1	1
	Volts	208/230	208/230	208/230	208/230	208/230	208/230	208/230	208/230
	Phase	1	1	1	1	1	1	1	1
	HP	1/3	1/3	1/3	1/3	1/3	1/3	1/3	1/3
	Amps (FLA, each)	1.5	1.5	1.5	1.5	1.5	1.5	1.5	1.5
	Amps (LRA, each)	3	3	3	3	3	3	3	3
Evaporator Fan	No.	1	1	1	1	1	1	1	1
	Volts	208/230	208/230	208/230	208/230	208/230	208/230	208/230	208/230
	Phase	1	1	1	1	1	1	1	1
	HP	1/3	1/3	1/3	1/3	1/3	1/2	1/2	1/2
	Amps (FLA, each)	2.8	2.8	2.8	2.8	2.8	4.1	4.1	4.1
	Amps (LRA, each)								

ELECTRICAL DATA - RGEAZR SERIES

		030AJT06U	030AJT081/X	036ACT061/X	036ACT06U	036ACT081/X	036ACT08U	036ACT101/X	036ADT061/X
Unit Information	Unit Operating Voltage Range	187-253	187-253	187-253	187-253	187-253	187-253	187-253	414-506
	Volts	208/230	208/230	208/230	208/230	208/230	208/230	208/230	460
	Phase	1	1	3	3	3	3	3	3
	Hz	60	60	60	60	60	60	60	60
	Minimum Circuit Ampacity	21	21	20	20	20	20	20	10
	Minimum Overcurrent Protection Device Size	25	25	25	25	25	25	25	15
	Maximum Overcurrent Protection Device Size	30	30	25	25	25	25	25	15
Compressor Motor	No.	1	1	1	1	1	1	1	1
	Volts	208/230	208/230	208/230	208/230	208/230	208/230	208/230	460
	Phase	1	1	3	3	3	3	3	3
	RPM	3500	3500	3500	3500	3500	3500	3500	3500
	HP, Compressor 1								
	Amps (RLA), Comp. 1	12.3	12.3	8.5	8.5	8.5	8.5	8.5	3.8
	Amps (LRA), Comp. 1	63	63	70	70	70	70	70	31
	HP, Compressor 2								
	Amps (RLA), Comp. 2								
Amps (LRA), Comp. 2									
Condenser Motor	No.	1	1	1	1	1	1	1	1
	Volts	208/230	208/230	208/230	208/230	208/230	208/230	208/230	460
	Phase	1	1	1	1	1	1	1	1
	HP	1/3	1/3	1/3	1/3	1/3	1/3	1/3	1/3
	Amps (FLA, each)	1.5	1.5	1.5	1.5	1.5	1.5	1.5	0.8
	Amps (LRA, each)	3	3	3	3	3	3	3	1.6
Evaporator Fan	No.	1	1	1	1	1	1	1	1
	Volts	208/230	208/230	208/230	208/230	208/230	208/230	208/230	460
	Phase	1	1	1	1	1	1	1	1
	HP	1/2	1/2	1	1	1	1	1	1
	Amps (FLA, each)	4.1	4.1	7.6	7.6	7.6	7.6	7.6	4
	Amps (LRA, each)								

ELECTRICAL DATA - RGEAZR SERIES

		036ADT06U	036ADT081/X	036ADT08U	036ADT101/X	036AJT061/X	036AJT06U	036AJT081/X	036AJT08U
Unit Information	Unit Operating Voltage Range	414-506	414-506	414-506	414-506	187-253	187-253	187-253	187-253
	Volts	460	460	460	460	208/230	208/230	208/230	208/230
	Phase	3	3	3	3	1	1	1	1
	Hz	60	60	60	60	60	60	60	60
	Minimum Circuit Ampacity	10	10	10	10	28	28	28	28
	Minimum Overcurrent Protection Device Size	15	15	15	15	35	35	35	35
	Maximum Overcurrent Protection Device Size	15	15	15	15	40	40	40	40
Compressor Motor	No.	1	1	1	1	1	1	1	1
	Volts	460	460	460	460	208/230	208/230	208/230	208/230
	Phase	3	3	3	3	1	1	1	1
	RPM	3500	3500	3500	3500	3500	3500	3500	3500
	HP, Compressor 1								
	Amps (RLA), Comp. 1	3.8	3.8	3.8	3.8	14.7	14.7	14.7	14.7
	Amps (LRA), Comp. 1	31	31	31	31	75	75	75	75
	HP, Compressor 2								
	Amps (RLA), Comp. 2								
Amps (LRA), Comp. 2									
Condenser Motor	No.	1	1	1	1	1	1	1	1
	Volts	460	460	460	460	208/230	208/230	208/230	208/230
	Phase	1	1	1	1	1	1	1	1
	HP	1/3	1/3	1/3	1/3	1/3	1/3	1/3	1/3
	Amps (FLA, each)	0.8	0.8	0.8	0.8	1.5	1.5	1.5	1.5
	Amps (LRA, each)	1.6	1.6	1.6	1.6	3	3	3	3
Evaporator Fan	No.	1	1	1	1	1	1	1	1
	Volts	460	460	460	460	208/230	208/230	208/230	208/230
	Phase	1	1	1	1	1	1	1	1
	HP	1	1	1	1	1	1	1	1
	Amps (FLA, each)	4	4	4	4	7.6	7.6	7.6	7.6
	Amps (LRA, each)								

ELECTRICAL DATA - RGEAZR SERIES

		036AJT101/X	042ACT081/X	042ACT08U	042ACT101/X	042AJT081/X	042AJT08U	042AJT101/X	048ACT081/X
Unit Information	Unit Operating Voltage Range	187-253	187-253	187-253	187-253	187-253	187-253	187-253	187-253
	Volts	208/230	208/230	208/230	208/230	208/230	208/230	208/230	208/230
	Phase	1	3	3	3	1	1	1	3
	Hz	60	60	60	60	60	60	60	60
	Minimum Circuit Ampacity	28	22	22	22	28	28	28	26
	Minimum Overcurrent Protection Device Size	35	25	25	25	35	35	35	30
	Maximum Overcurrent Protection Device Size	40	30	30	30	40	40	40	35
Compressor Motor	No.	1	1	1	1	1	1	1	1
	Volts	208/230	208/230	208/230	208/230	208/230	208/230	208/230	208/230
	Phase	1	3	3	3	1	1	1	3
	RPM	3500	3500	3500	3500	3500	3500	3500	3500
	HP, Compressor 1								
	Amps (RLA), Comp. 1	14.7	10.6	10.6	10.6	15.9	15.9	15.9	12.6
	Amps (LRA), Comp. 1	75	118	118	118	112.3	112.3	112.3	123
	HP, Compressor 2								
	Amps (RLA), Comp. 2								
Amps (LRA), Comp. 2									
Condenser Motor	No.	1	1	1	1	1	1	1	1
	Volts	208/230	208/230	208/230	208/230	208/230	208/230	208/230	208/230
	Phase	1	1	1	1	1	1	1	1
	HP	1/3	1/3	1/3	1/3	1/3	1/3	1/3	1/3
	Amps (FLA, each)	1.5	2	2	2	2	2	2	2
	Amps (LRA, each)	3	3.9	3.9	3.9	3.9	3.9	3.9	3.9
Evaporator Fan	No.	1	1	1	1	1	1	1	1
	Volts	208/230	208/230	208/230	208/230	208/230	208/230	208/230	208/230
	Phase	1	1	1	1	1	1	1	1
	HP	1	3/4	3/4	3/4	3/4	3/4	3/4	1
	Amps (FLA, each)	7.6	6	6	6	6	6	6	7.6
	Amps (LRA, each)								

ELECTRICAL DATA - RGEAZR SERIES

		048ACT08U	048ACT101/X	048ACT10U	048ADT081/X	048ADT101/X	048ADT10U	048AJT081/X	048AJT08U
Unit Information	Unit Operating Voltage Range	187-253	187-253	187-253	414-506	414-506	414-506	187-253	187-253
	Volts	208/230	208/230	208/230	460	460	460	208/230	208/230
	Phase	3	3	3	3	3	3	1	1
	Hz	60	60	60	60	60	60	60	60
	Minimum Circuit Ampacity	26	26	26	13	13	13	36	36
	Minimum Overcurrent Protection Device Size	30	30	30	15	15	15	45	45
	Maximum Overcurrent Protection Device Size	35	35	35	15	15	15	50	50
Compressor Motor	No.	1	1	1	1	1	1	1	1
	Volts	208/230	208/230	208/230	460	460	460	208/230	208/230
	Phase	3	3	3	3	3	3	1	1
	RPM	3500	3500	3500	3500	3500	3500	3500	3500
	HP, Compressor 1								
	Amps (RLA), Comp. 1	12.6	12.6	12.6	6	6	6	19.9	19.9
	Amps (LRA), Comp. 1	123	123	123	60	60	60	109	109
	HP, Compressor 2								
	Amps (RLA), Comp. 2								
	Amps (LRA), Comp. 2								
Condenser Motor	No.	1	1	1	1	1	1	1	1
	Volts	208/230	208/230	208/230	460	460	460	208/230	208/230
	Phase	1	1	1	1	1	1	1	1
	HP	1/3	1/3	1/3	1/3	1/3	1/3	1/3	1/3
	Amps (FLA, each)	2	2	2	1	1	1	2	2
	Amps (LRA, each)	3.9	3.9	3.9	2.2	2.2	2.2	3.9	3.9
Evaporator Fan	No.	1	1	1	1	1	1	1	1
	Volts	208/230	208/230	208/230	460	460	460	208/230	208/230
	Phase	1	1	1	1	1	1	1	1
	HP	1	1	1	1	1	1	1	1
	Amps (FLA, each)	7.6	7.6	7.6	4	4	4	8.9	8.9
	Amps (LRA, each)								

ELECTRICAL DATA - RGEAZR SERIES

		048AJT101/X	048AJT10U	060ACT081/X	060ACT101/X	060ACT10U	060ADT081/X	060ADT101/X	060ADT10U
Unit Information	Unit Operating Voltage Range	187-253	187-253	187-253	187-253	187-253	414-506	414-506	414-506
	Volts	208/230	208/230	208/230	208/230	208/230	460	460	460
	Phase	1	1	3	3	3	3	3	3
	Hz	60	60	60	60	60	60	60	60
	Minimum Circuit Ampacity	36	36	29	29	29	14	14	14
	Minimum Overcurrent Protection Device Size	45	45	35	35	35	15	15	15
	Maximum Overcurrent Protection Device Size	50	50	40	40	40	15	15	15
Compressor Motor	No.	1	1	1	1	1	1	1	1
	Volts	208/230	208/230	208/230	208/230	208/230	460	460	460
	Phase	1	1	3	3	3	3	3	3
	RPM	3500	3500	3500	3500	3500	3500	3500	3500
	HP, Compressor 1								
	Amps (RLA), Comp. 1	19.9	19.9	14	14	14	6.5	6.5	6.5
	Amps (LRA), Comp. 1	109	109	93	93	93	60	60	60
	HP, Compressor 2								
	Amps (RLA), Comp. 2								
Amps (LRA), Comp. 2									
Condenser Motor	No.	1	1	1	1	1	1	1	1
	Volts	208/230	208/230	208/230	208/230	208/230	460	460	460
	Phase	1	1	1	1	1	1	1	1
	HP	1/3	1/3	1/2	1/2	1/2	1/2	1/2	1/2
	Amps (FLA, each)	2	2	2.3	2.3	2.3	1.2	1.2	1.2
	Amps (LRA, each)	3.9	3.9	5.5	5.5	5.5	3	3	3
Evaporator Fan	No.	1	1	1	1	1	1	1	1
	Volts	208/230	208/230	208/230	208/230	208/230	460	460	460
	Phase	1	1	1	1	1	1	1	1
	HP	1	1	1	1	1	1	1	1
	Amps (FLA, each)	8.9	8.9	8.9	8.9	8.9	4	4	4
	Amps (LRA, each)								

ELECTRICAL DATA - RGEAZR SERIES

		060AJT081/X	060AJT101/X	060AJT10U
Unit Information	Unit Operating Voltage Range	187-253	187-253	187-253
	Volts	208/230	208/230	208/230
	Phase	1	1	1
	Hz	60	60	60
	Minimum Circuit Ampacity	41	41	41
	Minimum Overcurrent Protection Device Size	50	50	50
	Maximum Overcurrent Protection Device Size	60	60	60
Compressor Motor	No.	1	1	1
	Volts	208/230	208/230	208/230
	Phase	1	1	1
	RPM	3500	3500	3500
	HP, Compressor 1			
	Amps (RLA), Comp. 1	23.5	23.5	23.5
	Amps (LRA), Comp. 1	118	118	118
	HP, Compressor 2			
	Amps (RLA), Comp. 2			
Amps (LRA), Comp. 2				
Condenser Motor	No.	1	1	1
	Volts	208/230	208/230	208/230
	Phase	1	1	1
	HP	1/2	1/2	1/2
	Amps (FLA, each)	2.3	2.3	2.3
	Amps (LRA, each)	5.5	5.5	5.5
Evaporator Fan	No.	1	1	1
	Volts	208/230	208/230	208/230
	Phase	1	1	1
	HP	1	1	1
	Amps (FLA, each)	8.9	8.9	8.9
	Amps (LRA, each)			

Sure Comfort® RGEAZR iR Packaged Gas Electric Unit

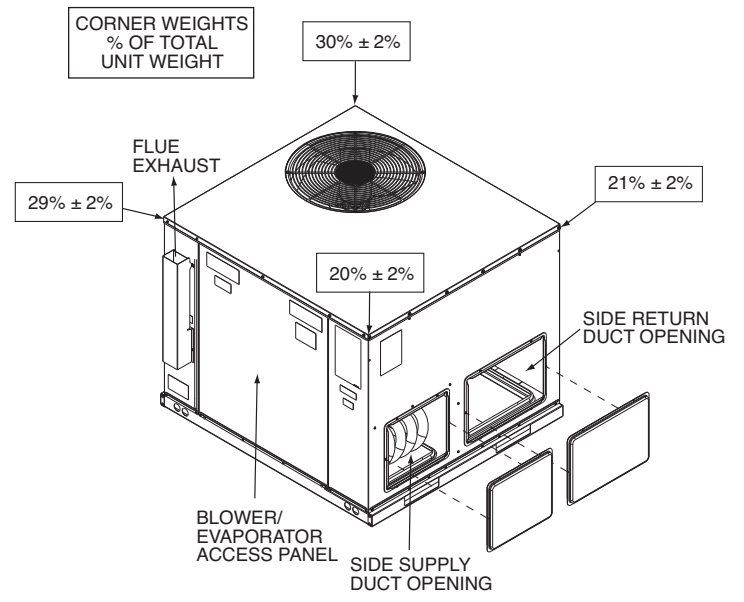
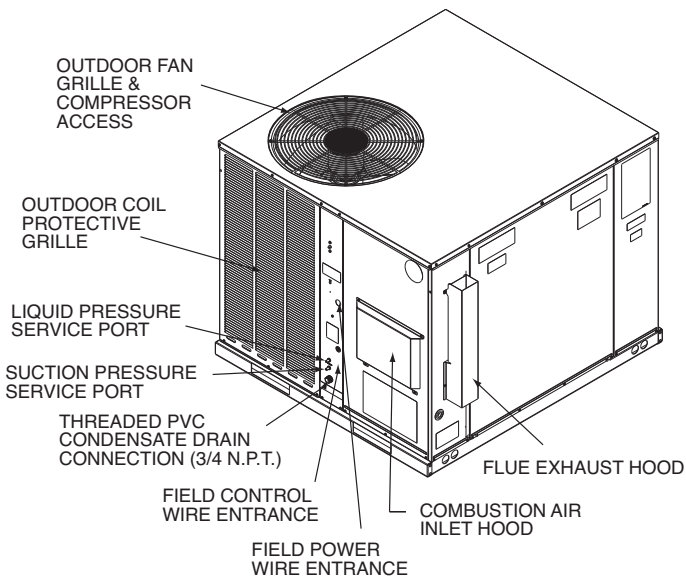

TOP VIEW

BOTTOM VIEW

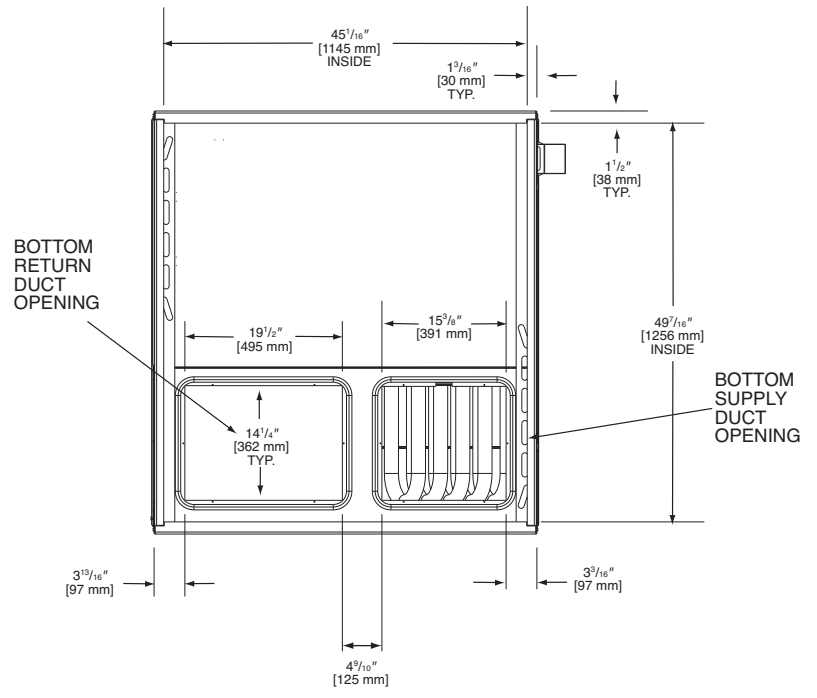
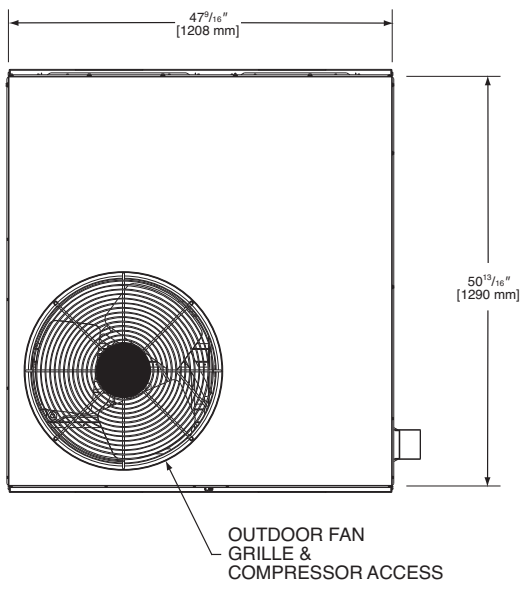

[] Designates Metric Conversions

SIDE VIEW

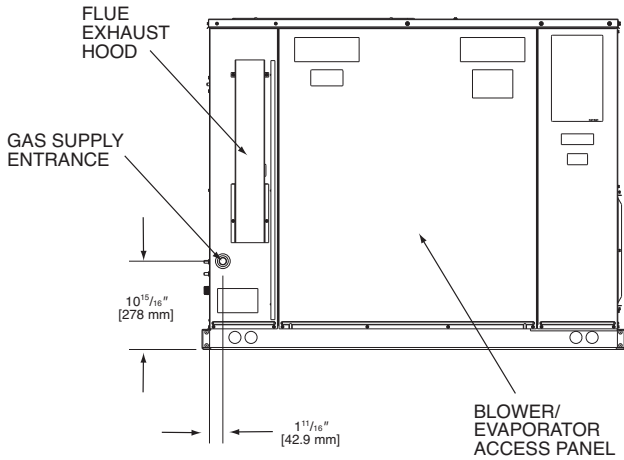

SIDE VIEW

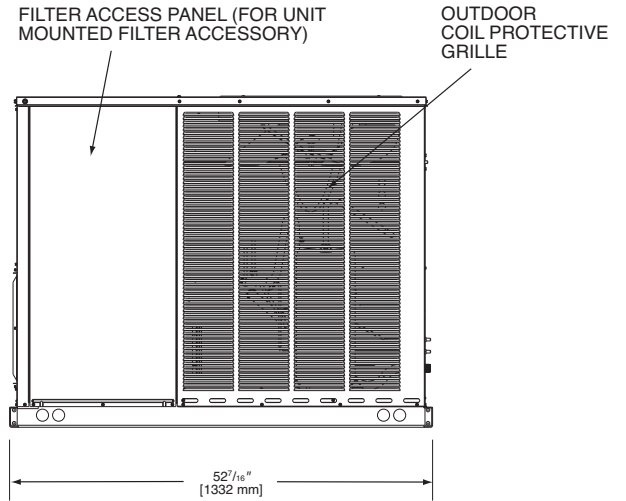

FRONT VIEW

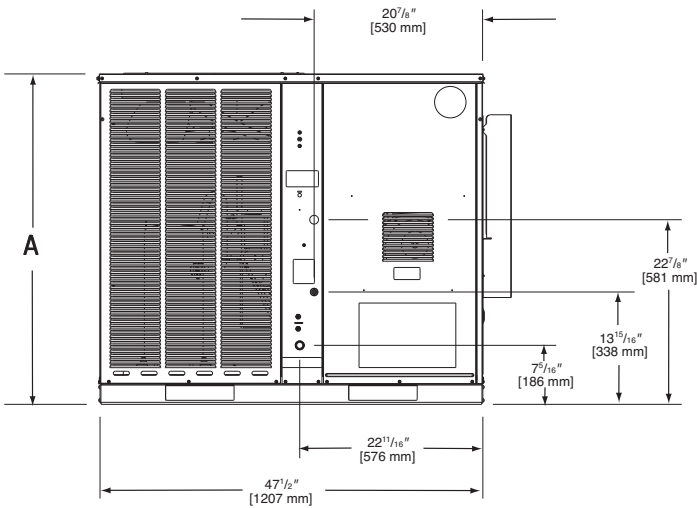

BACK VIEW

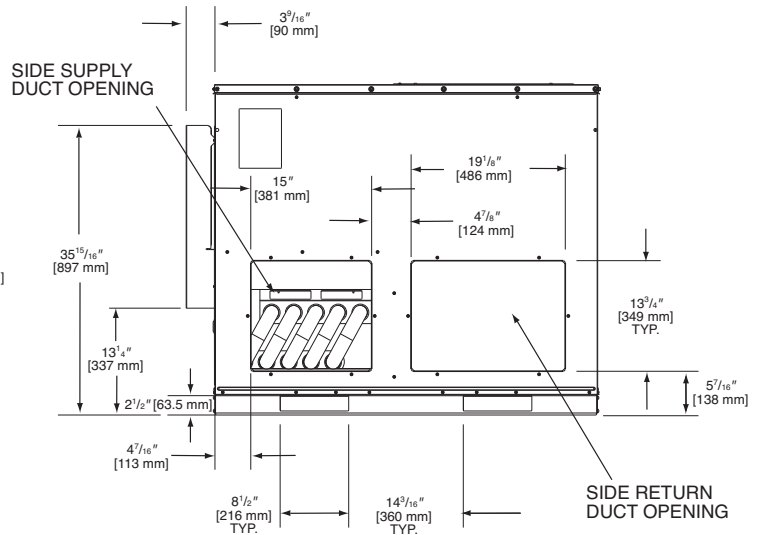

SHOWN WITH DUCT COVERS REMOVED.

Models RGEAZR	Height "A"
024, 030, 036	$35^{15}/16"$
042, 048, 060	41"

[] Designates Metric Conversions

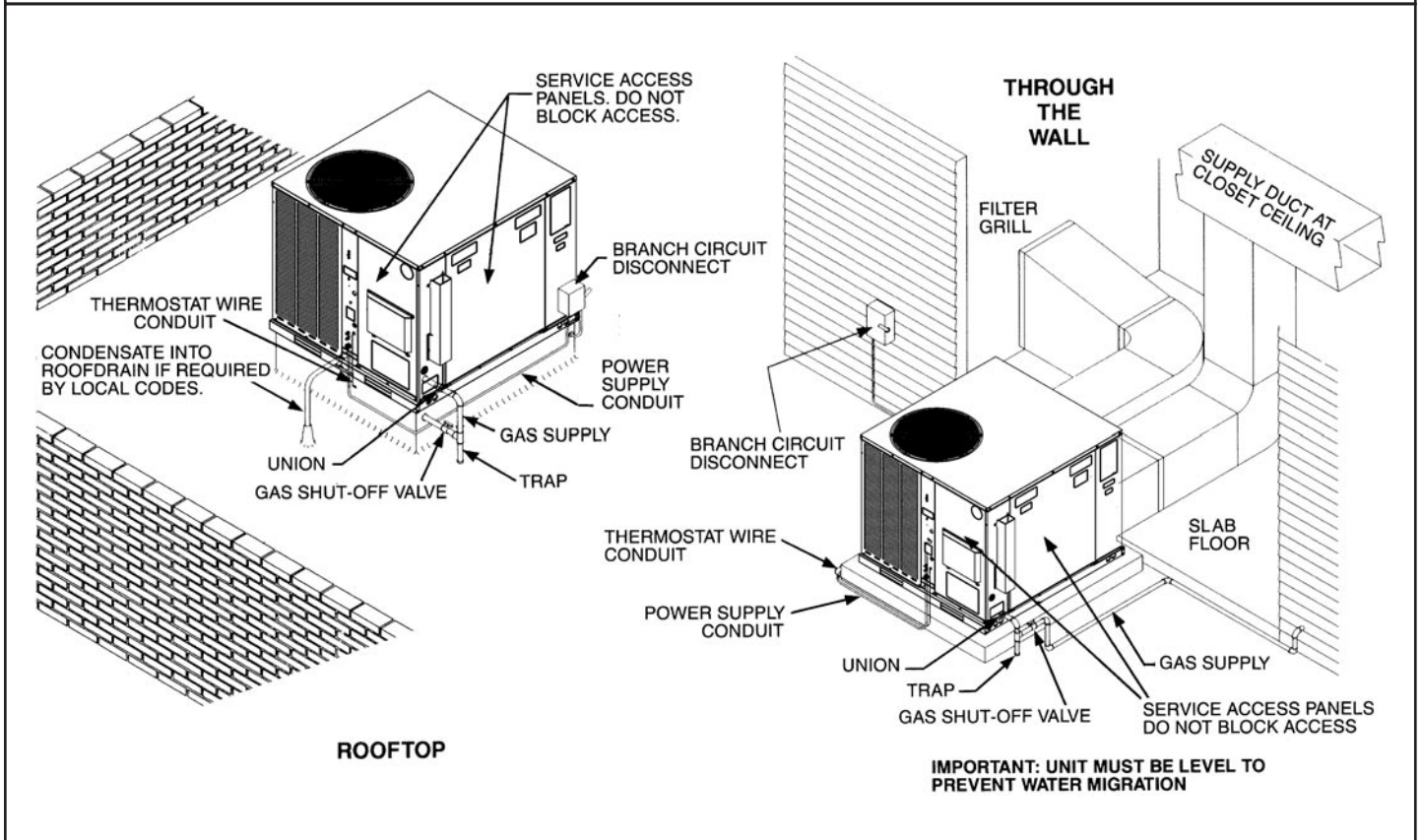
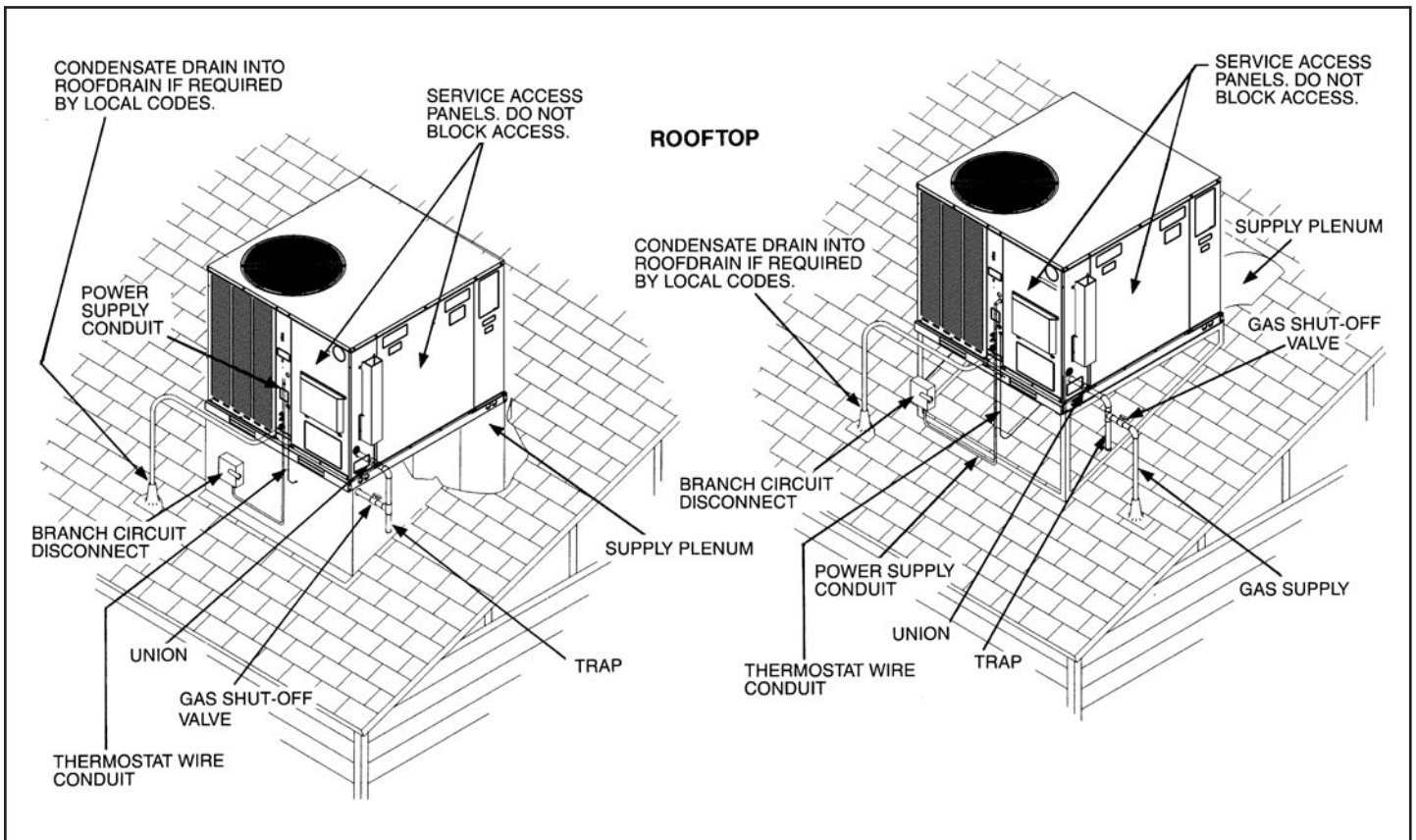

[] Designates Metric Conversions

ACCESSORY EQUIPMENT

Accessory Description	Model Application	Accessory Model No.
Roofcurbs	RGEAZR	RXSG-AAA08 (8" [203 mm] Height) RXSG-AAA14 (14" [356 mm] Height)
Supply & Return Diffusers	RGEAZR	RXRN-BD15
Economizers (Convertible)	RGEAZR	AXRD-01RACAM3
Fresh Air Damper	RGEAZR	AXRF-FAB1 (Motorized-35%) AXRF-FAA1 (Fixed-35%)
Rectangular to Round Transition (Downflow)	RGEAZR	RXMC-CA02 (16" [406 mm] Ducts) RXMC-CA03 (18" [457 mm] Ducts)
Filter Kit	RGEAZR	RXRY-B01
Sideflow Rectangular to Round Transition	RGEAZR	AXMC-BA01
LP Conversion Kits	RGEAZR	RXGJ-EP84W (White-Rodgers Gas Valve) RXGJ-EP85H (Honeywell Gas Valve) RXGJ-FP28
Low Ambient Control	RGEAZR	RXRZ-B01
High Pressure Control	RGEAZR ²	RXAB-E01
Low Pressure Control	RGEAZR ²	RXAC-C01
Canadian High Altitude Kit (for Natural Gas only ¹)	RGEAZR	RXR- AH01

¹ If a particular unit is to be converted to operate on LP (propane) for elevations above 2000 ft. [609.6 m] in Canada, the existing Natural Gas to LP Conversion Kits for the subject models already contain the necessary orifices and instructions to de-rate the input for 2000-4500 ft. [609.6-1371.6 m] Canadian applications.

² High pressure switches are standard for RGEA Models.

[] Designates Metric Conversions

COMMON SUPPLY/RETURN

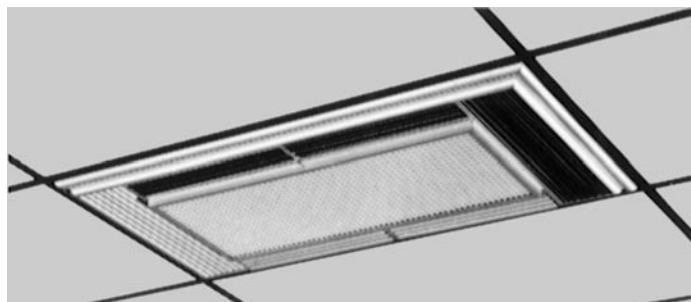

SUPPLY/RETURN DIFFUSER

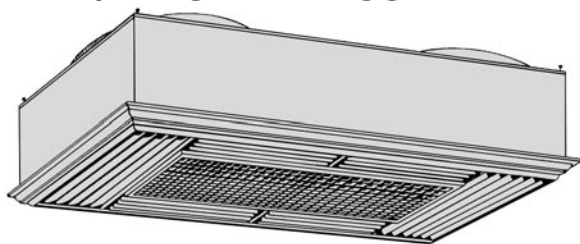

Designed to convert a side by side or an over and under arrangement into a concentric distribution of air. The diffuser is flush mounted, completely insulated, assembled, and internally baffled to provide four way supply air distribution with a center return. To make the assembly complete and ready to fit into a 2' [0.61 m] x 4' [1.22 m] suspended ceiling grid, the diffuser includes adjustable supply louvers, hanging rings, anti-sweat gasket, and round flanges for use with flexible ducts.

Model No.	Diameter Inches [mm]	Shipping Wt. Lbs. [kg]	Dimension A Inches [mm]
RXRN-BD15	16 [406]	90 [40.82]	20 1/2 [521]

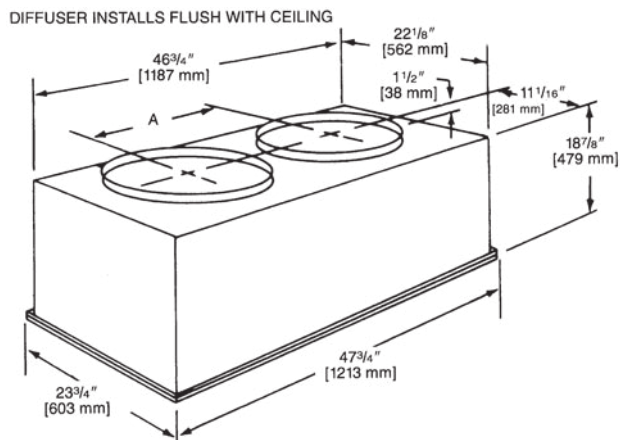

NOTE: The location of the combination supply and return diffuser should not exceed 10 feet [3.05 m] above the floor level for units @ 1000 CFM [472 L/s] or less and 12 [3.66 m] to 14 feet [4.27 m] above the floor level for units with CFM greater than 1000 [472 L/s]. If the diffuser is installed with a greater distance than recommended above, the supply air may become stratified above the required comfort area causing uncomfortable conditions.

AIRFLOW/PRESSURE DROP INFORMATION (INCHES W.C. [kPa])

Accessory	Approximate CFM [L/s]-Supply Air			
	1300 [614]	1575 [743]	1800 [850]	2200 [1038]
Plenum & Supply/Return Duct	.07 [.017]	.10 [.024]	.12 [.030]	.17 [.042]
Diffuser	.09 [.022]	.13 [.032]	.16 [.040]	.24 [.060]
Economizer	.06 [.015]	.09 [.022]	.11 [.027]	.17 [.042]

SUPPLY AIR/PERFORMANCE

Diffuser Airflow CFM [L/s]	Range of Throw Ft. [m]
800 [378]-1200 [566]	14 [4.27]-16 [4.88]
1600 [755]-2000 [944]	18 [5.49]-28 [8.53]

DUCT ADAPTERS RECTANGULAR TO ROUND TRANSITIONS (DOWNFLOW)

RXMC-CA02

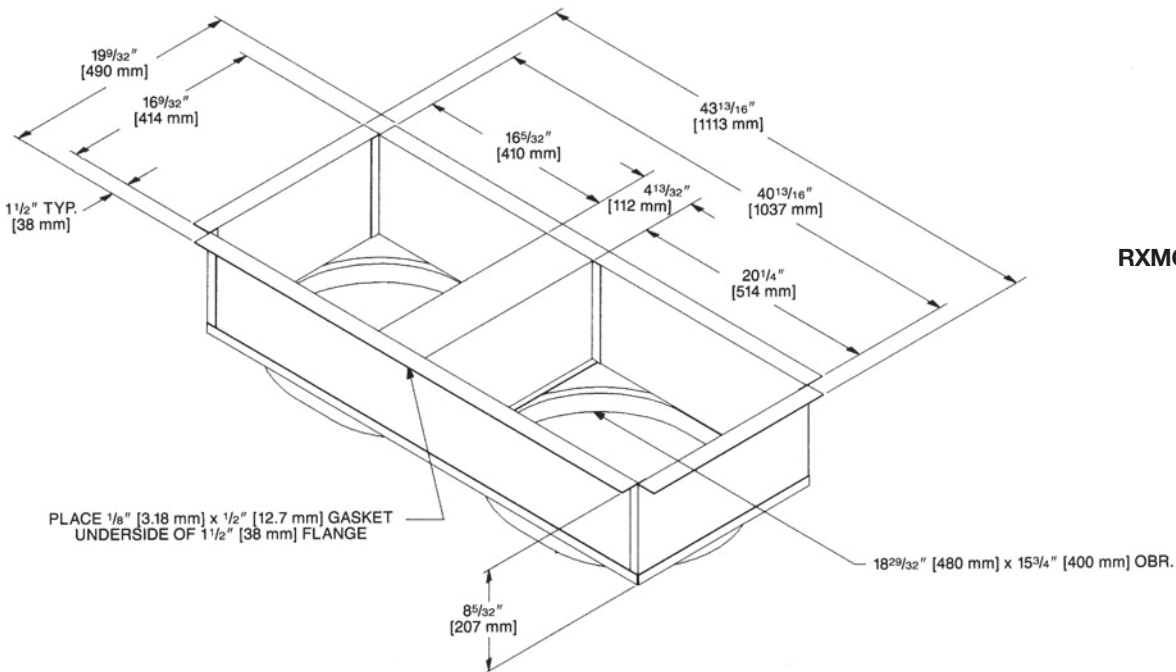
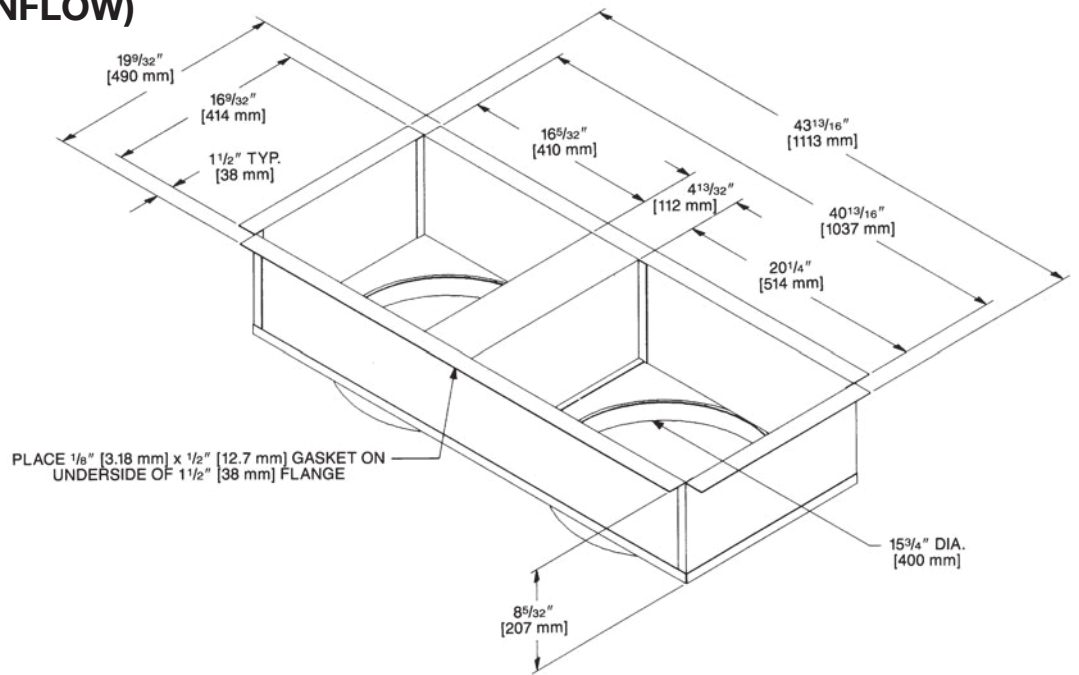

RXMC-CA03

[] Designates Metric Conversions

FRESH AIR DAMPER

AXRF-FAA1 (Fixed - 0-35%)

The 0-35% manual outside Air Damper is designed to replace the unit return air duct cover. No drilling or damper assembly is required. The amount of outside air (0-35%) is controlled by simply adjusting the side damper.

AXRF-FAB1 (Motorized - 0-35%)

The 0-35% motorized outside Air Damper is designed to replace the unit return air duct cover. No drilling or damper assembly is required. The control motor opens the adjustable slide damper when the unit blower motor is energized.

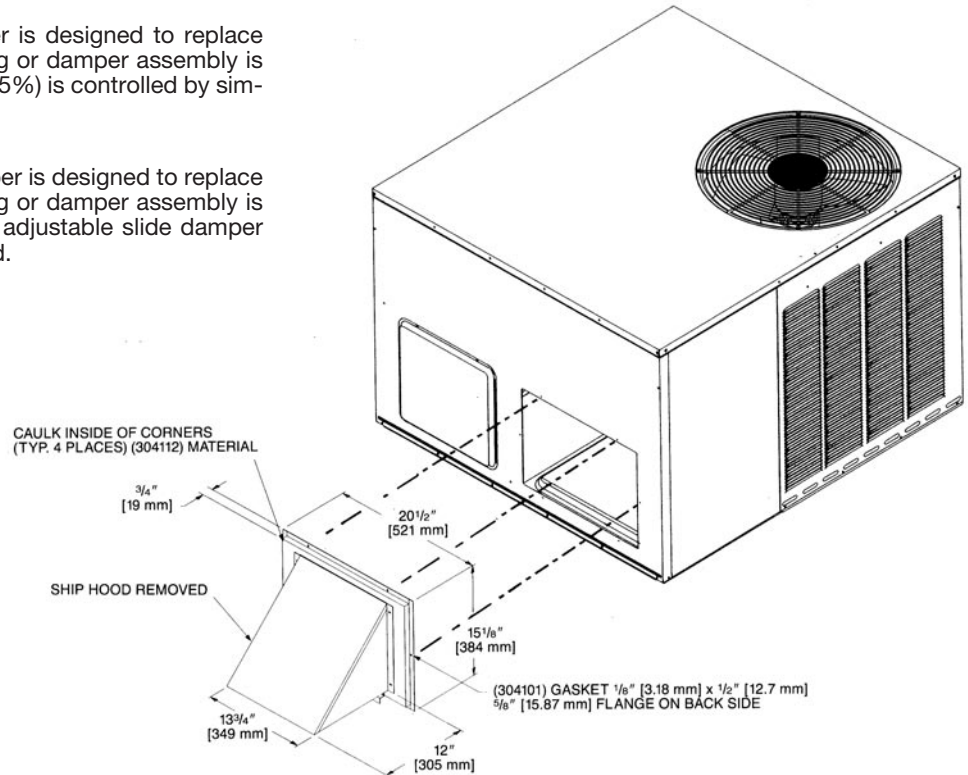

[] Designates Metric Conversions

ECONOMIZERS

AXRD-01RACAM3 (Fully Modulating) Horizontally and Vertically Applicable

- LCD Screen for Continuous diagnostic and system status
- Programmable set points for accurate positioning
- Simplified wiring and color coded terminals
- Onboard fault detection and diagnostics (FDD)
- Operational Checkout to verify installation
- Enthalpy sensors and actuator that communicate through a Sylk Bus Network with the Jade Controller reducing wiring errors while providing more information
- CO₂ sensor input for DCV (Demand Control Ventilation) applications
- RXXR-AV04 Dual Enthalpy kit available for field installation
- AMCA licensed class 1A low leak Dampers

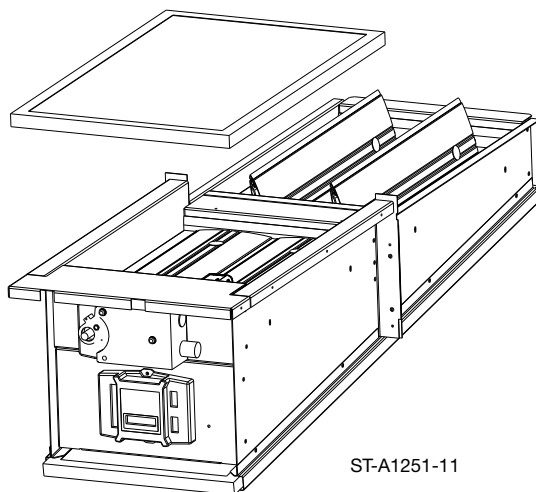
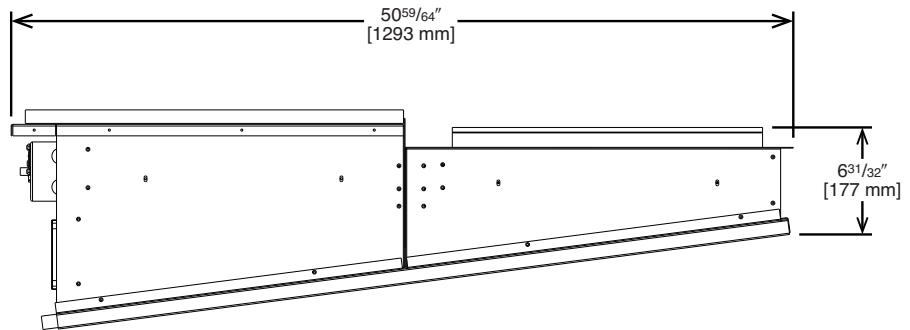
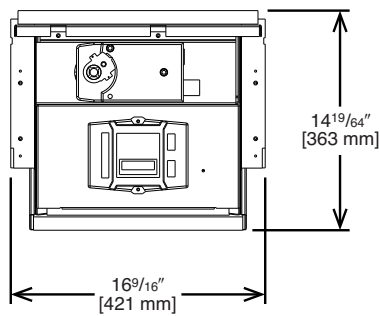
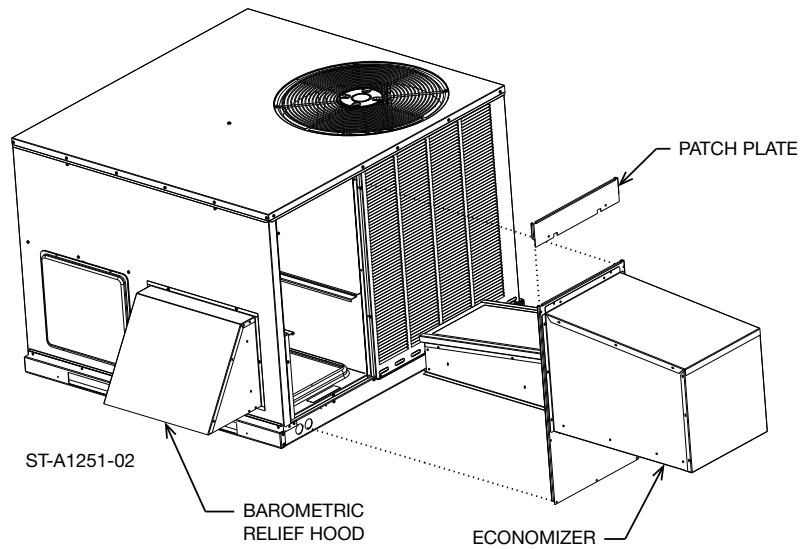

[] Designates Metric Conversions

FILTER KIT INSTALLATION RXRY-B01

For use in either
vertical or horizontal
discharge.

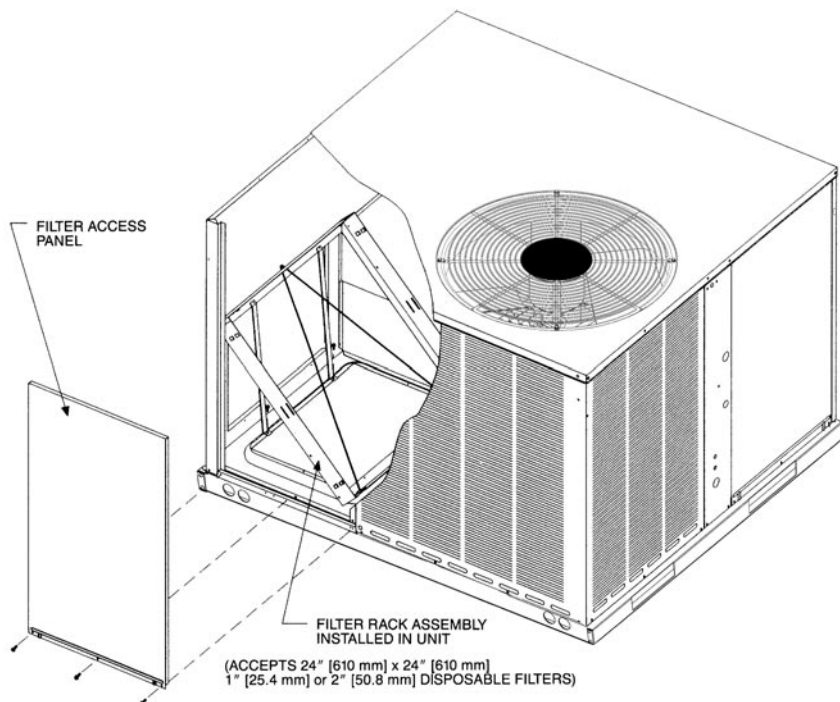

Airflow Pressure Drop, Inches W.C. [kPa]		
CFM [L/s]	1" Filter	2" Filter
500 [236]	.02 [.0050]	.03 [.0075]
600 [283]	.02 [.0050]	.03 [.0075]
700 [330]	.03 [.0075]	.04 [.0010]
800 [378]	.04 [.0010]	.05 [.0124]
900 [425]	.05 [.0124]	.06 [.0149]
1000 [472]	.07 [.0174]	.08 [.0199]
1100 [519]	.08 [.0199]	.09 [.0224]
1200 [566]	.10 [.0249]	.12 [.0299]
1300 [614]	.13 [.0324]	.15 [.0373]
1400 [661]	.16 [.0398]	.19 [.0473]
1500 [708]	.19 [.0473]	.21 [.0523]
1600 [755]	.20 [.0498]	.23 [.0572]
1700 [802]	.21 [.0523]	.24 [.0598]
1800 [850]	.22 [.0548]	.25 [.0623]
1900 [897]	.24 [.0598]	.27 [.0672]
2000 [944]	.26 [.0647]	.29 [.0722]

[] Designates Metric Conversions

DUCT ADAPTER SIDEFLOW SQUARE TO ROUND TRANSITION AXMC-BA01

Adapts the side rectangular supply and return openings to 14" [356 mm] diameter round openings. Adapters provided with same finish as unit and also provided with thermal insulation.

[] Designates Metric Conversions

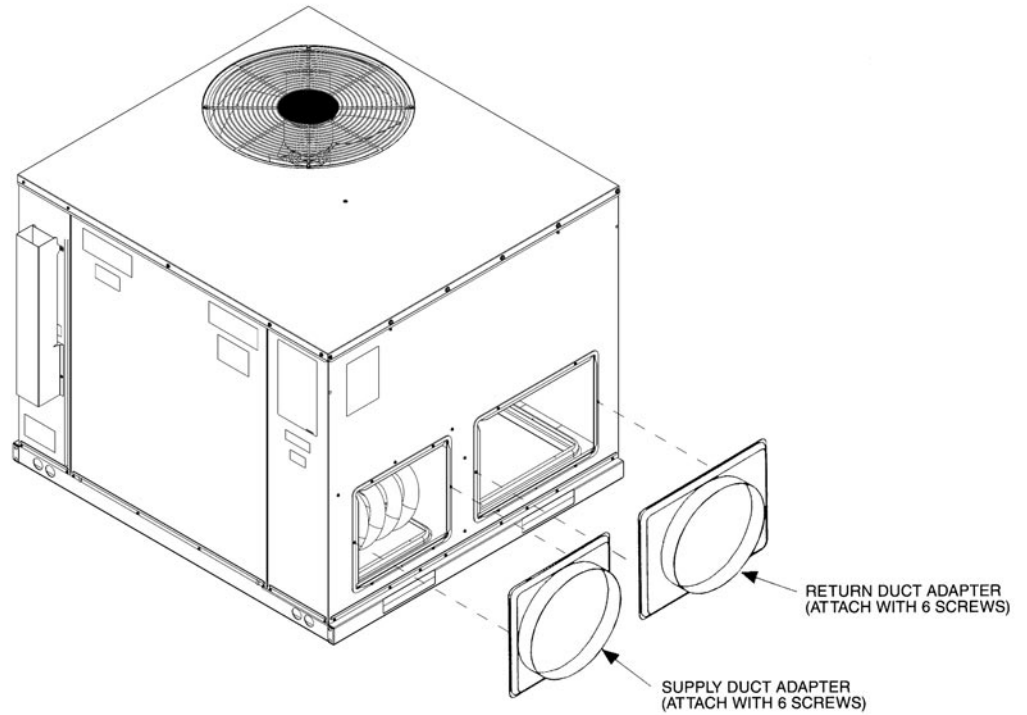

ROOFCURB (Full Perimeter)

RXSG-AAA08, RXSG-AAA14

Hinged corners make for fast, easy set-up.

RXSG-AAA08
(8" [203 mm] High)

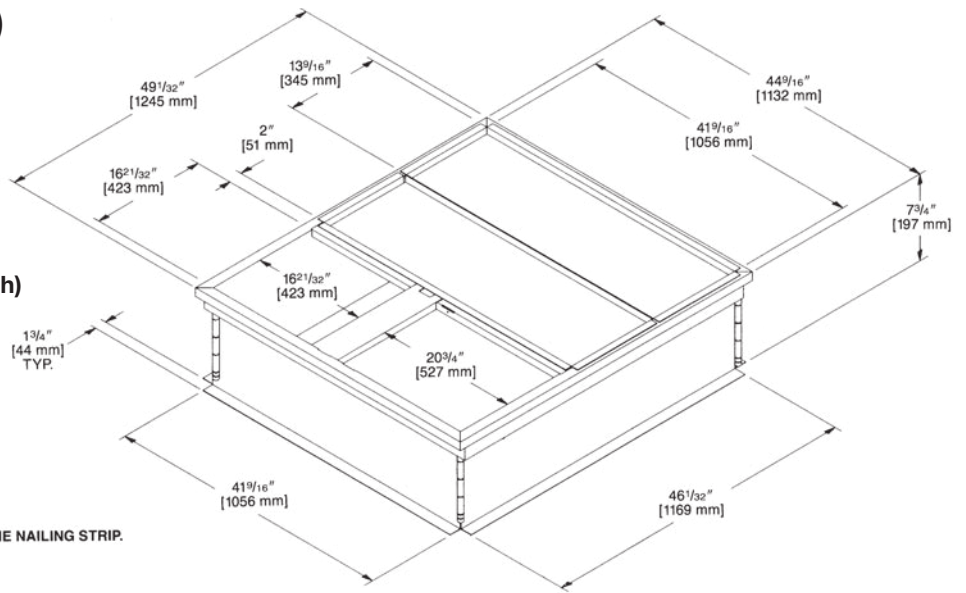

NOTE: PERIMETER OF ROOFCURB IS SUPPLIED WITH A NOMINAL 1" [25.4 mm] x 4" [102 mm] PINE NAILING STRIP.

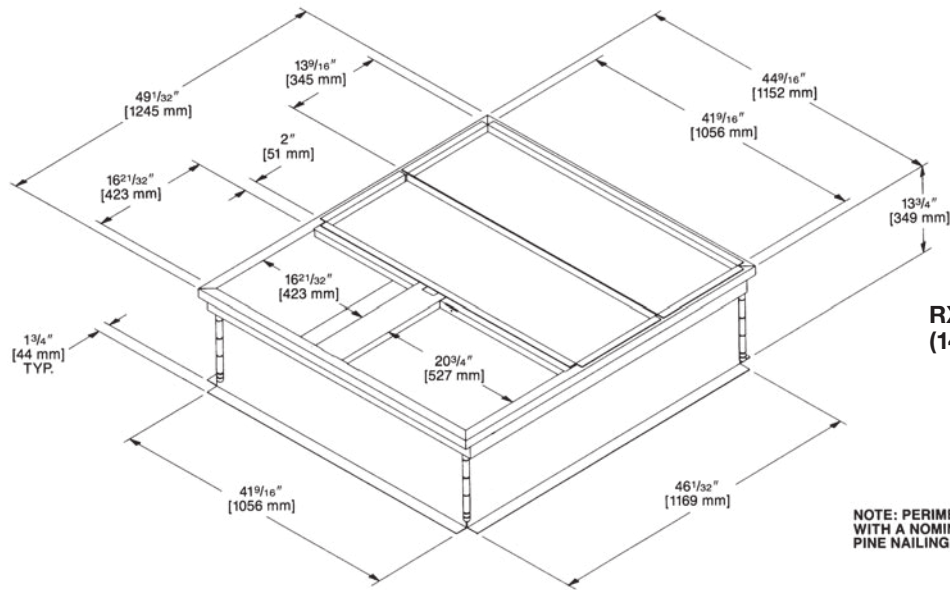

RXSG-AAA14
(14" [356 mm] High)

NOTE: PERIMETER OF ROOFCURB IS SUPPLIED WITH A NOMINAL 1" [25.4 mm] x 4" [102 mm] PINE NAILING STRIP.

[] Designates Metric Conversions

BEFORE PURCHASING THIS APPLIANCE, READ IMPORTANT ENERGY COST AND EFFICIENCY INFORMATION AVAILABLE FROM YOUR RETAILER.

GENERAL TERMS OF LIMITED WARRANTY*

Sure Comfort® will furnish a replacement for any part of this product which fails in normal use and service within the applicable periods stated, in accordance with the terms of the limited warranty.

Heat Exchanger

- Factory StandardTen (10) Years
- Stainless Steel/1-Phase & 3-Phase Models
- Commercial Application.....Twenty (20) Years
- Stainless Steel/1-Phase Models
- Residential ApplicationLimited Lifetime

Conditional Parts (Registration Required)

- 1 Phase, Residential Applications.....Ten (10) Years

Compressor

- 1 Phase, Residential Applications.....Ten (10) Years
- 1 & 3 Phase, Commercial Applications.....Five (5) Years

Parts

- Commercial Applications.....One (1) Year

*For complete details of the Limited and Conditional Warranties, including applicable terms and conditions, contact your local contractor or the Manufacturer for a copy of the product warranty certificate.

© 2023 Rheem Manufacturing Company. Sure Comfort trademarks owned by Rheem Manufacturing Company.

In keeping with its policy of continuous progress and product improvement, Sure Comfort reserves the right to make changes without notice.



Sure Comfort®

5600 Old Greenwood Road, Fort Smith, AR 72908

Before proceeding with installation, refer to installation instructions packaged with each model, as well as complying with all Federal, State, Provincial, and Local codes, regulations, and practices.